

# SAVE VTR 200/B L 1000W

Item no. 14883

Version: Filter F7-G3

Document type: **Product card**

Document date: **2016-04-20**

Generated by: **Systemair Online Catalogue**



## Description

- High efficient rotary heat exchanger
- Energy efficient RadiCal-fans, with modern EC technology
- Separate settings of supply and extract air flow
- Start-up wizard for easy commissioning
- Automatic change to summer operation (without heat recovery)
- Demand control regulation as standard by the built-in humidity sensor
- Low sound level
- Modbus communication via RS-485

SAVE VTR 200/B is a white painted model with an integrated control panel in the front door. The option for connecting one or more external control panels is also available. Connection to an external cooker hood is available on the top of the unit. This makes the unit well suited for apartment buildings where the extract air from the cooker hood is challenging.

The unit is double skinned, fully insulated and with complete control functions, high efficiency rotating heat exchanger, thermostat operated re-heater battery and filters. Energy efficient fans with EC motors will reduce energy consumptions. With these, up to 50% less energy consumption can be achieved in comparison to AC solutions, with the noise behavior decreased by one-half. Modern technology gives low SFP factor (Specific Fan Power).

SAVE VTR 200/B is adapted for ventilation of smaller houses and apartments with an area of 140 m<sup>2</sup>. The extract air from the cooker hood is being by-passed, hence the heat exchanger is not being exposed to extract air from the kitchen.

Commissioning of the unit will be done from the CD control panel in the front door or a separate external panel. A start-up wizard will make the commissioning easier, which can avoid that the unit is running at wrong conditions. Symbols and text in the display will indicate chosen settings; Supply air temperature and fan speed. Commissioning of airflow on supply and extract, will be done at start-up but can be set from the menu settings as well. Timer-function for automatic change between day and night operation is integrated. Setting of filter period is also available. Alarm signal will indicate possible malfunctions.

The CD panel also has a user level for authorized installers and service personnel. An external CD panel is connected to the unit by means of cable with quick connectors (modular plugs), at the top of the unit.

The unit is provided with outputs for control of external hot water or cooling battery and comes with built-in humidity sensor in extract air that enables demand control regulation with respect to moisture. It also has functions available for external demand control that gives effective and economical operation. For instance, CO<sup>2</sup>, presence or humidity sensor.

The unit is delivered with supply air filter F7 and extract air filter G3. Option for G3 supply air filter is available.



## Technical parameters

Unit		
Frequency	50	Hz
Weight	46	kg
Recommended fuse	10	A
Enclosure class	IP24	IP

Airflow range	0..252	m <sup>3</sup> /h
Voltage	230	V
Phase	1	~

#### Heat exchanger

Exchanger type	Rotating
----------------	----------

#### Heater

Input power, electrical heating battery	1	kW
Heating type	Electric	

#### Supply filter

Filter, supply air	F7 (Standard)
--------------------	---------------

#### Extract filter

Filter, extract air	G3 (Standard)
---------------------	---------------

#### Others

Mounting type	Vertical
Supply side	Left

#### ErP

Energy class, basic unit	A
Energy class, basic unit option	A
ErP ready	ErP 2018/ErP 2016

#### Supply fan

Input power (P1)	84	W
------------------	----	---

#### Extract fan

Input power (P1)	84	W
------------------	----	---

## Performance

### Diagrams

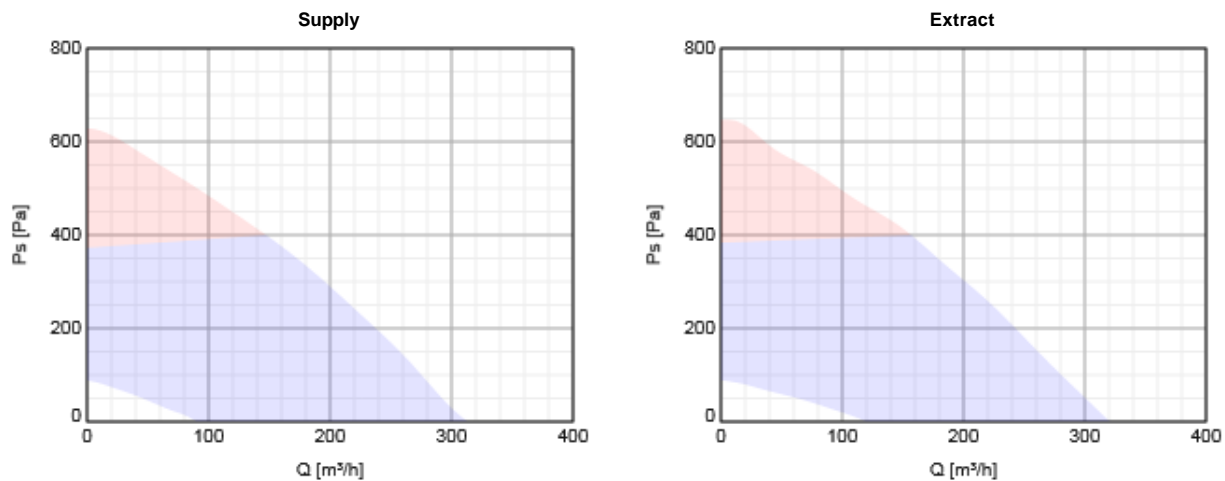

Diagrams and calculations are made for the performance with clean filters.

## Dimensions

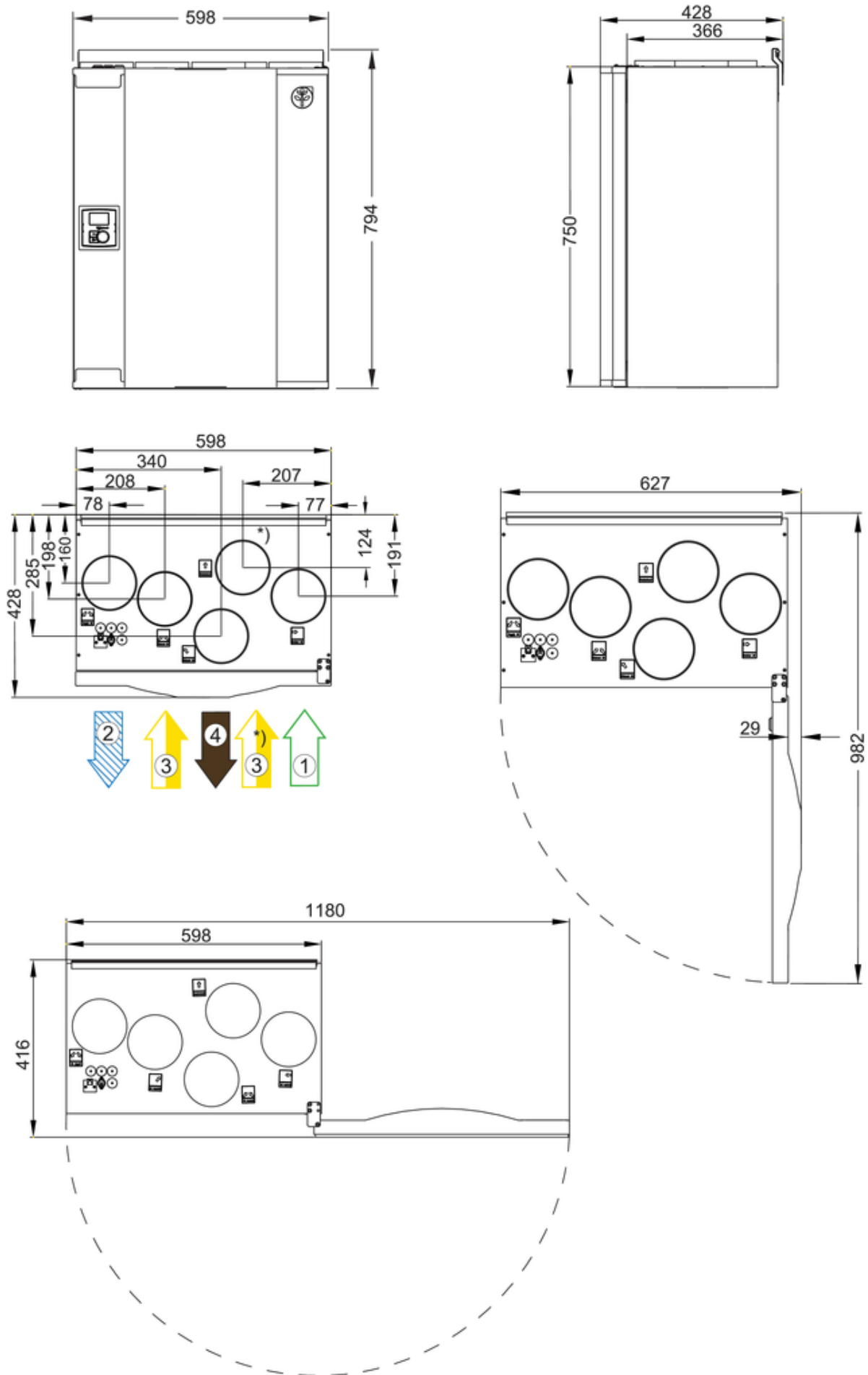

1	Outdoor air
2	Supply air
3	Extract air
4	Exhaust air

\*) = Connection for cooker hood

Connection Ø 125 mm (5x)

### Wiring

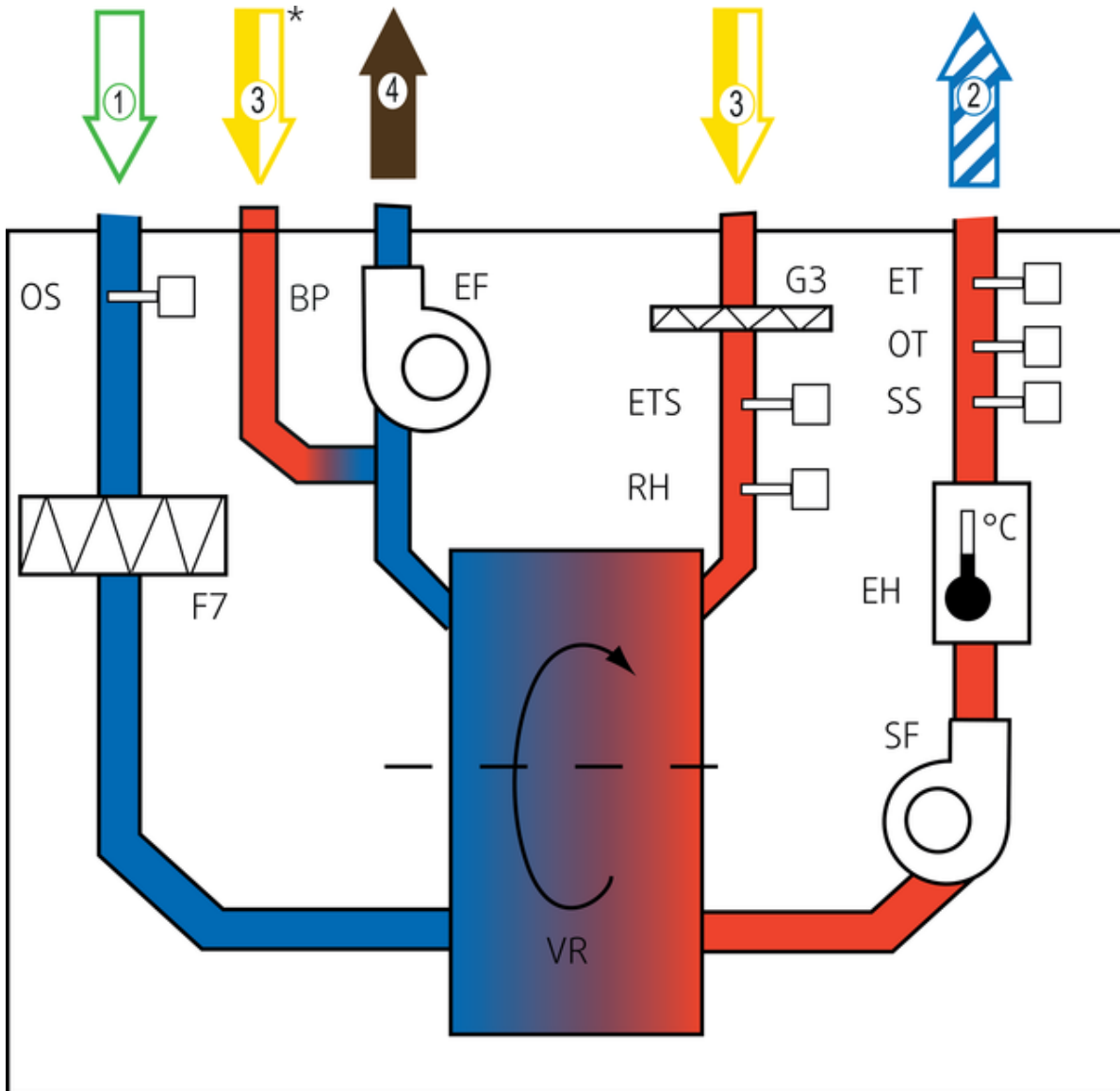

F7 = Filter outdoor air  
VR = Rotary heat recovery unit  
EF = Extract fan  
G3 = Filter extract air  
G4 = Extract/Supply filter (only for VTC unit)  
ETS = Extract air temp. sensor  
SF = Supply fan  
EH = Electric heater  
SS = Supply air temp. sensor  
OT = Overheating thermostat  
ET = Emergency thermostat  
EHS = Exhaust air sensor  
OS = Outdoor air sensor  
BP = Bypass cooker hood  
BD = Bypass integrated cooker hood  
DB = Bypass damper  
RH = Relative humidity sensor  
1 = Outdoor air  
2 = Supply air  
3 = Extract air  
4 = Exhaust air

Wiring diagram

 SAVE\_VTR\_200\_300\_500\_WD\_208063\_en-GB (A006).pdf (303,54kB)

## Accessories

### Electric accessories

CO2RT-R-D Transmitter (6993)  
Presence detector/IR24-P (6995)  
Push button, impulse (9693)  
251-10/B Cookerh.EV/B,EH/B wh. (12023)  
TG-A130 Surface sensor 0-30°C (5159)  
HR1 Room Humidistat IP21 (5150)  
F-T120 Timer frame (5137)  
T 120 Timer (5165)  
TG-K360 Duct sensor 0-60°C (4846)  
U-EK plastic housing AP1R IP54 (30198)  
RVAZ4 24A Actuator 0-10V (9862)  
PSS48 Transformer 24V (204385)  
PSS20 Transformer 24V (202692)  
251-10/B Cookerh EVB,EHB steel (12929)  
CEC Cable w/plug 12m (24782)  
CEC Cable w/plug 6m (24783)  
CO2 Sensor Wireless (25126)  
Humidity Sensor Wireless (25127)  
Input Module Wireless (25128)  
SmartDial (25129)  
RS485 Gateway Wireless (25130)  
CE/CD-diverting plug 4pin (37367)  
602-10/B Cookerhood White (47561)  
602-10/B Cookerhood S.Steel (47562)

### Accessories

ZTR 15-0,4 valve 3-way (9670)  
VBC 125-2 Water heating batt (5457)  
ZTV 15-0,4 2-way valve (9829)  
VBC 125-3 Water heating batt (9839)  
ZTV 15-0,6 2-way valve (6571)  
ZTR 15-0,6 valve 3-way (6573)  
LDC 125-600 Silencer (5190)  
LDC 125-900 Silencer (5191)  
Connectduct Ø 125/1,0 M/F (2556)  
CWK 125-3-2,5 Duct cooler,circ (30021)  
FK 125 Fast clamp (1608)  
GEO heat exchanger box (312513)  
BFVTR 200/B G3 Extract Air (207937)  
BFVTR 200/B G3 Supply Air (207938)  
BFVTR 200/B F7 Supply Air (207939)  
Drain pipe kit VTR 200/B (207999)  
Duct Cover White VTR 200/B (19577)  
CVVX 125 Combi grille, black (26421)  
CVVX 125 Combi grille, white (26422)  
RDR-80/15-50m³/h (37293)

## Documentation

 SAVE\_VTR200\_Installation\_and\_service\_208061\_CE\_en-GB (A005).pdf (1,41MB)

 SAVE\_VTR200\_User\_manual\_208062\_en-GB (A003).pdf (1,04MB)

 VTR\_200\_B\_Installation\_Guide\_Drain pipe\_208001.pdf (151,84kB)

 Modbus for Residential units\_D24810\_User\_manual (A005).pdf (263,77kB)

 CD panel Instruction for wall mounting 206858 GB\_SE.pdf (221,37kB)

 Eurovent Certification Diploma 20160125095348,227.pdf (1,78MB)

 VTR 200B L.dxf (1,18MB)

## Eco design

Units with local demand control	
Trade name	Systemair
Product name	SAVE VTR 200/B L 1000W
ErP compliance	2018
SEC Average	-39,1 kWh/ (m <sup>2</sup> .a)
SEC Cold	-82,2 kWh/ (m <sup>2</sup> .a)
SEC Warm	-14,4 kWh/ (m <sup>2</sup> .a)
SEC Class	A
Unit category	RVU
Unit type	BVU
Drive	Intergated VSD
Heat recovery type	Regenerative
Temperature ratio	82 %
qv max	0,713 m <sup>3</sup> /s
P max	180 W
Sound power	40 dB(A)
qv ref	0,5 m <sup>3</sup> /s
Ps ref	50 Pa
SPI	1,57 kW/ (m <sup>3</sup> /s)
CTRL	0,65 -
MISC	1,1 -
x-value	2 -
External Leakage	3 %
Internal Leakage	4 %
Type of product	RAHU/AARE
AEC average	231 kWh
AEC cold	231 kWh
AEC warm	231 kWh
AHS Average	4528 kWh/a
AHS Cold	8857 kWh/a
AHS Warm	2047 kWh/a

Basic unit		
Trade name	Systemair	
Product name	SAVE VTR 200/B L 1000W	
ErP compliance	2018	
SEC Average	-34,2	kWh/ (m <sup>2</sup> .a)
SEC Cold	-76,4	kWh/ (m <sup>2</sup> .a)
SEC Warm	-10,1	kWh/ (m <sup>2</sup> .a)
SEC Class	A	
Unit category	RVU	
Unit type	BVU	
Drive	Intergated VSD	
Heat recovery type	Regenerative	
Temperature ratio	82	%
qv max	0,0713	m <sup>3</sup> /s
P max	180	W
Sound power	40	dB(A)
qv ref	0,05	m <sup>3</sup> /s
Ps ref	50	Pa
SPI	1,57	kW/ (m <sup>3</sup> /s)
CTRL	0,85	-
MISC	1,1	-
x-value	2	-
External Leakage	3	%
Internal Leakage	4	%
Type of product	RAHU/AARE	
AEC average	396	kWh
AEC cold	396	kWh
AEC warm	396	kWh
AHS Average	4413	kWh/a
AHS Cold	8633	kWh/a
AHS Warm	1996	kWh/a

## Energy class label

## Energy class, basic unit

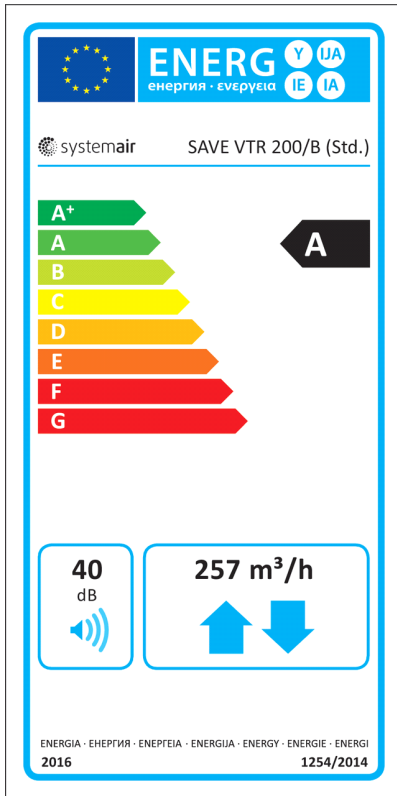

## Unit with local demand control

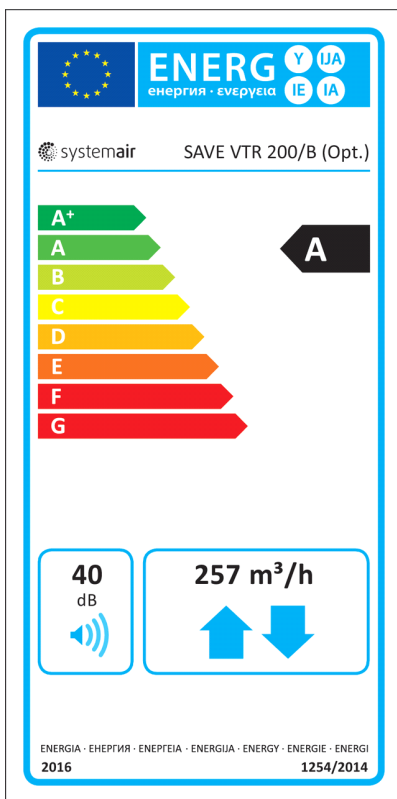

## EPS diagrams

## Specification text