

You make dreams a reality. We provide the efficient Air-Conditioning.

Genius – the intelligent central building services unit for heating, cooling, ventilation and water heating.

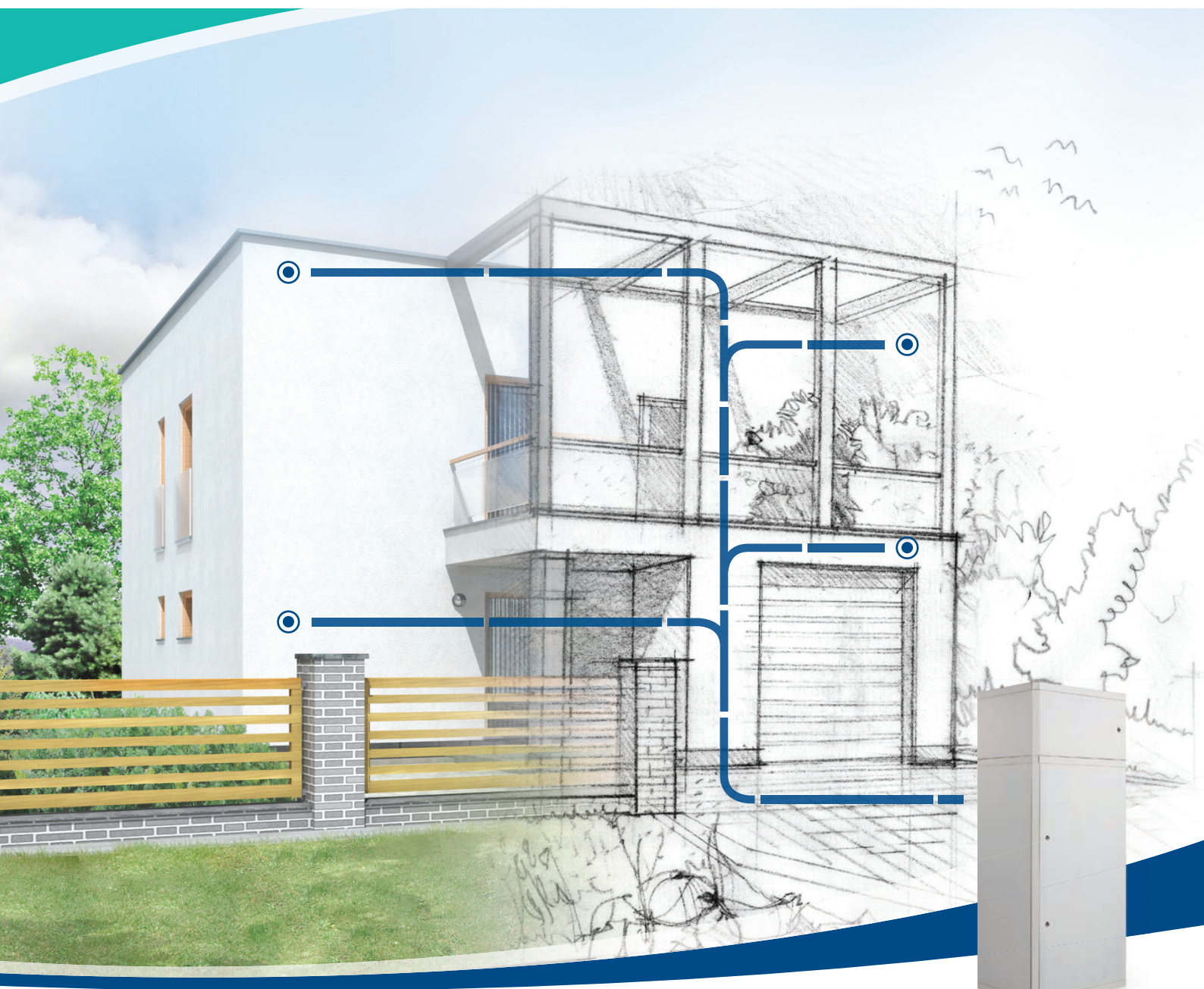



A breath of fresh air: Genius by Systemair.

| | |
|---------------------------------------|----|
| The principle of air heating | 4 |
| Genius Central Building Services Unit | 6 |
| Modules and Function | 10 |
| Schematic diagrams | 12 |
| Technical data | 14 |
| Accessories and Service | 16 |
| FAQs | 19 |



Every day you work passionately in bringing your dream homes to reality with your customers. We at Systemair share in this philosophy with intelligent technology operating energy efficiently perfectly adapted to the requirements of modern construction in all kinds of applications.

Our “Genius” Central Building services unit has been developed accordingly.

At last - 1 unit that can do everything from Heating, Cooling, Ventilation and Domestic Hot Water!

Discover these fresh ideas for your customers. And your business.

Where Oil, Gas and water once came – we now do it all with Air.

Air heating system from Systemair



Genius is the compact Central Building Services Unit which can do everything: ventilation, heating, cooling and hot water production. All Genius needs is a secondary air circuit in addition to the conventional ventilation ducts. Thanks to the integrated air/air heat pump, a heating system using water becomes unnecessary.

KEY

- Outdoor air
- Supply air
- Secondary air
- Extract air
- Exhaust air

Nowadays, whoever builds a new building or renovates an old one must fulfil the European Directive Energy Performance of Buildings (EPBD). The result is often highly insulated, airtight building envelopes which require mechanical residential ventilation – for a healthy indoor climate and as little energy loss as possible. At the same time, thanks to today's improved standards for insulation, the heating energy required is less. For this reason, classical heating systems are generally overdimensioned for energy-efficient houses. This is why we developed Genius. A central building services unit which with its integrated air-air heat pump is, on the one hand, able to ventilate efficiently with heat recovery, and on the other hand is able to use the air for heating or cooling the rooms. But that's not all: thanks to an integrated air-water heat pump, even hot water production is included. That is to say, you only need one system. This saves a great deal of time in the planning phase, reduces investment costs and, what's more, needs less space. Convincing arguments for demanding customers. And promising prospects for you

Poor Indoor Environment is History with the Genius unit

The idea of using air as a heat transfer medium and transporting it from room to room through ducts has been around a long time. However, until now it was common for unpleasant smells and impurities to be transported too. Thanks to Systemair's secondary air system, your customers will only experience pure air quality, because the extract air system remains completely untouched. This ensures that the transmission of odours or substances is excluded. Furthermore, high-quality pollen and dust filters clean the air. The result: the very best air quality and a pleasant indoor climate for your customers.

How the air heating system works

At the heart of the system is the Genius combi-unit. It continually supplies the living and sleeping quarters with fresh, clean air, and transports the extract air to the exterior, via the kitchen, bathroom and WC. A rotary heat exchanger removes the heat from the extract air and, if necessary, uses it to preheat the cool supply air. Furthermore, it ensures that the air is not too dry. In summer, the principle functions in reverse, so that the extract air cools the supply air and excessive ambient air humidity is removed.

Heating and cooling modes

The heating load is covered by an increase in the volumetric flow. Here a fan draws air from the living area via a separate duct system (secondary air). A stepless controlled air-air heat pump heats this depending on the requirements and conveys it to the living and sleeping quarters. In summer, the heat pump works in reverse so that the dwelling is cooled.

Hot water production

All the functions of Genius can be used individually or in parallel. This applies to hot water production as well. A 150 litre tank is integrated for storing the drinking water. A heating rod is installed inside to ensure the system functions perfectly, even if the outside temperatures are extremely low.

One for all. All with air.

Genius – the modern central building services unit

Genius from Systemair is the intelligent solution for detached energy-efficient houses*. Saving space, it combines controlled residential ventilation including heat recovery (up to 85%) with heating / cooling and hot water production. In combination with a photovoltaic system, it is even possible to realise a virtually self-sufficient and CO2 neutral system. Best of all: with Genius you save a lot of time in the planning phase, because Systemair will take on the entire project engineering for you.

Advantageous. For your customers and for you.

All the functions of Genius are possible independently or in parallel operation – just as you need them. This means the optimum utilisation of the required energy and conservation of resources. Additional electric heating is only necessary in exceptional situations, since Genius is equipped with modern, powerful heat pump technology.

This makes high room temperatures possible, even on very cold days. If your customer still wants to have a multi-fuel or wood-burning stove, or a tiled stove, there is nothing to stop them: the heat from the stove is distributed throughout the entire house via the secondary air. In summer, the stepless controlled heat pump works in reverse, actively cooling the ambient air. This way, your customer can enjoy an ideal indoor climate and the highest level of comfort throughout the whole year with just one system.

By the way: Genius can easily be operated via the Internet. This means you and your customers have unlimited access, even from outside. Clever, don't you think?



Good for the environment and the budget

Modern buildings require a ventilation system. So the expenditure for this is unavoidable. However, with Genius you save by not having to install a separate distribution system for the heating, which also results in lower maintenance costs. Furthermore, Genius is an absolute pioneer with regard to efficiency, making the operating costs comparable or cheaper than for other systems.

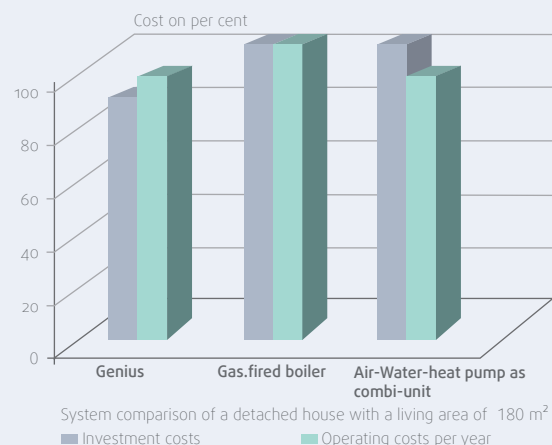





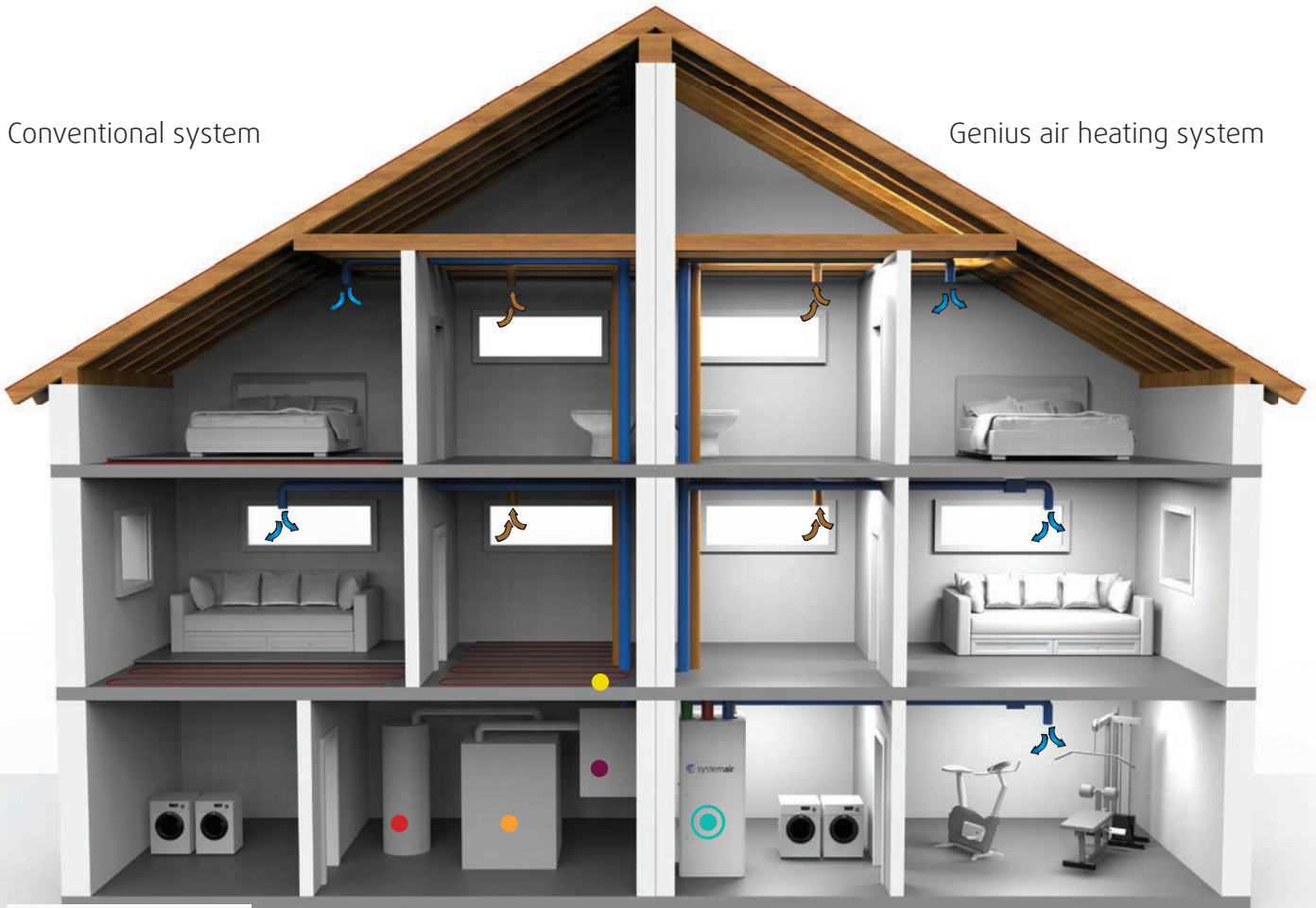

Increased comfort, decreased space requirement



KEY

-  Genius
-  Hot water tank
-  Boiler
-  Air handling unit
-  Underfloor heating

! Good to know

The individual Genius components for ventilation, the heat pump and hot water are installed in compact modules, which can simply be pushed into the housing or placed on top. This makes installation and maintenance easier.

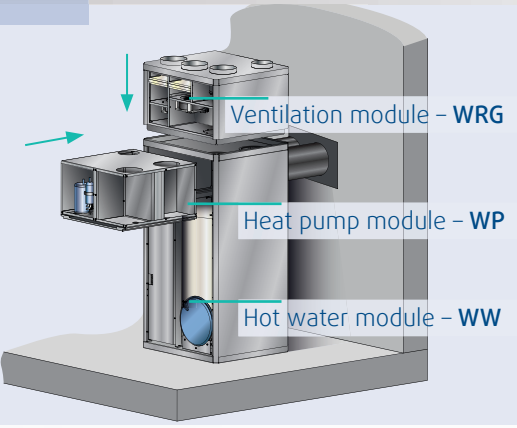

● **An overview of all the advantages of Genius:**

- Humidity recovery via rotary heat exchanger
- Low space requirement
- Control system optimises consumption
- Easy to operate: via display, app, Internet, cloud
- Advanced components from renowned manufacturers (ebmpapst, Danfoss, Carel, Regin, Mitsubishi)
- PLUS X AWARD innovation prize

- In general, no additional heating is necessary – not even on very cold days
- Heat recovery up to 85%
- Project engineering by Systemair
- Integrated 150 litre drinking water storage tank
- Reversible heat pump
- Contemporary, dimensioned for the requirements of energy-efficient houses

- Can be used with independent fireplace.
- Possible to combine with photovoltaics





Ventilation module

- Rotary heat exchanger with humidity recovery
- Heating and cooling of the building via the ventilation system's supply air ducts.



Heat pump module



- With stepless controlled compressor for precise adjustment
- Reversible air-air/air-water heat pump for heating/cooling/hot water



Hot water module

- Incl. control cabinet and 150 L hot water tank
- Hot water production parallel to heating and cooling operation



Comfortable in all areas.

Modules, control, functions



Modern technology requires contemporary, convenient operation. This is why we have designed Genius so that you and your customers can control the system easily with a PC and even via the Internet: as an expert via the service level and as an end user via the user level. This enables you and your customers to have permanent

access, even from outside, and an optimum overview of all functions and parameters. Control of individual rooms via a display is just as easy as controlling the system via an operating panel on the unit. The Systemair App permits you to control the system using your mobile phone.

The functions in detail:

- 4 ventilation steps according to DIN 1946/6:
 - Ventilation for humidity protection
 - Reduced ventilation
 - Nominal ventilation
 - Intensive ventilation
 - Additional option to switch off
- Temperature control in the winter:
 - Setpoint adjustment based on external temperature
 - Temperature control of individual rooms
 - Fixed value
 - Setpoint = average setpoint temperature for the room
 - Setpoint = Reference room setpoint
- Temperature control in the summer:
 - Setpoint adjustment based on external temperature
 - Fixed value
 - Cooling can be deactivated
- Fireplace operation
- Legionella control program
- Fast charging hot water
- Emergency mode hot water
- Emergency mode heating
- Adjustment of the maximum supply air temperature based on external temperature, alternatively manually
- Minimum supply air temperature
- Time programs:
 - Ventilation/heating/cooling
 - Hot water: automatic, individual
 - Decrease mode: setpoint temperature, ventilation stage
 - Holiday mode
- Filter monitoring
- Passive night-time cooling, individually adjustable
- Chart function: recording of conditions/parameters
- Electric reheating elements (PTCs):
 - Temperature control of individual rooms
 - Emergency operation
 - Start delay
 - Can be switched off

Thoroughly thought through.

Genius in operation

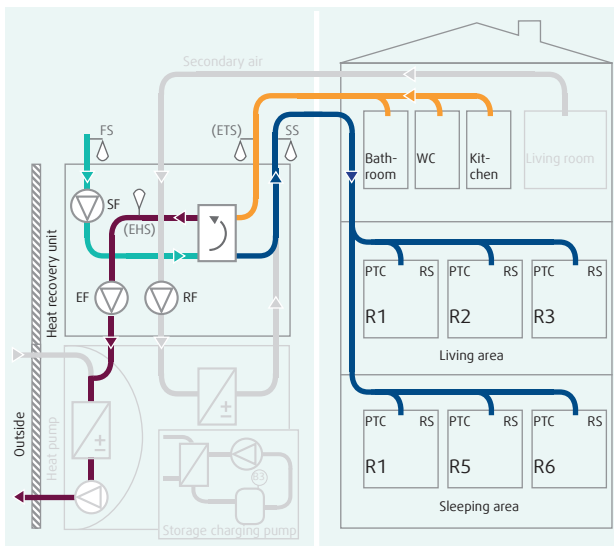

Ventilation mode

The extract air is extracted via the kitchen, bathroom and WC. On its way to the outside, it flows over the rotary heat exchanger. At the same time, fresh air is drawn in from the outside and is also passed through the rotary heat exchanger. With each rotation of the heat exchanger, both supply air and extract air flow through the cells.

In this way, heat from the extract air is transferred to the supply air. In summer, the principle functions in reverse, so that the cooler extract air pre-cools the warmer supply air.

As well as heat, the rotary heat exchanger also recovers humidity. This means that the atmospheric humidity is generally always within a comfortable range.

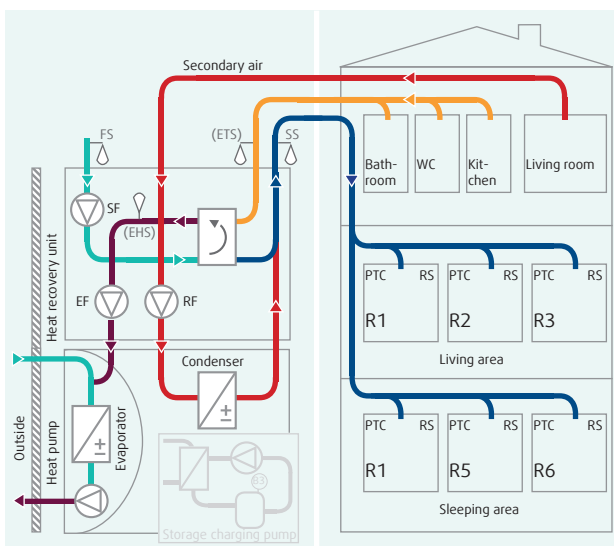

Heating mode

The heating load is covered by an increase in the volumetric flow. This requires a separate duct system. A fan, which is controlled in parallel to the heat pump, removes secondary air from the living area. This is warmed with the heat pump and fed back into the living and sleeping quarters as supply air.

The extract air system remains completely untouched, ensuring that contamination of the supply air is excluded. Only the residual energy in the exhaust air, after heat recovery, is used as an additional heat source by the heat pump.

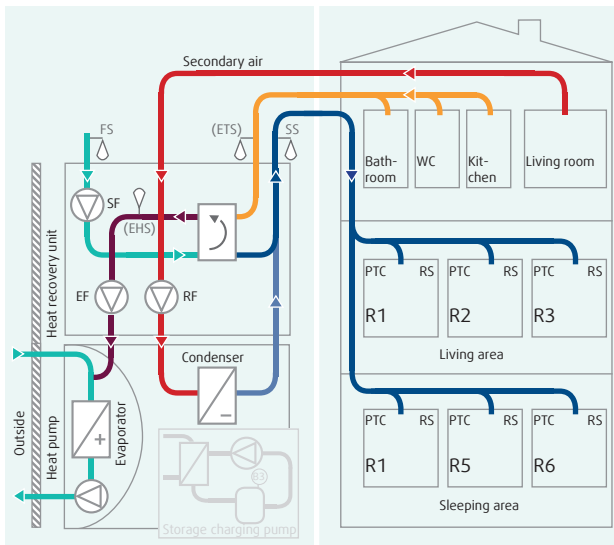

Cooling mode

The cooling mode works in the same way as the heating mode, except that the heat pump is working in reverse. This means that the evaporator becomes the condenser and the condenser becomes the evaporator. The heat pump extracts heat from the house or apartment, which is then discharged to the outside.

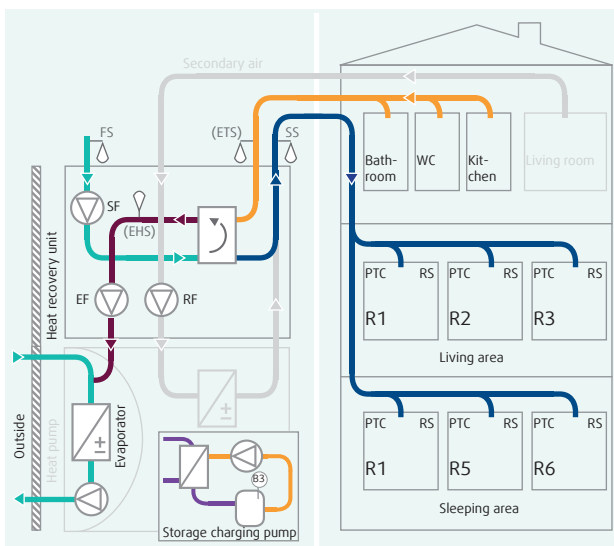

Hot water production without heating or cooling demand

The ventilation functions as described in "Ventilation mode". If there is a demand for hot water, the compressor and the storage charging pump start. The residual energy of the extract air is used as in the heating mode. A plate heat exchanger is used. The hot gas of the refrigeration circuit flows through the primary side and hot water flows through the secondary side.

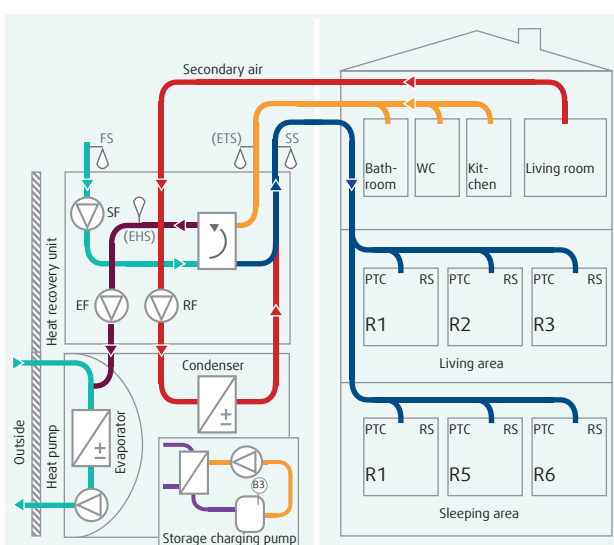

Hot water production in parallel with heating

Hot gas flows continuously through the plate heat exchanger for hot water production. The demand for hot water production only takes place via the charge pump. If heating is operating at the same time, the secondary air fan follows the heating demand. Now, the Domestic Hot water is heated preferentially. However the residual heat is used for the heating operation.

Hot water production in parallel with cooling functions according to the same principle.

| KEY | | | | | |
|-----|--------------------|-----|--------------------|--|---------------|
| SF | Supply air fan | SS | Supply air sensor | | Outdoor air |
| EF | Extract air fan | EHS | Exhaust air sensor | | Supply air |
| RF | Secondary air fan | PTC | PTC element | | Secondary air |
| FS | Outdoor air sensor | RS | Room controller | | Extract air |
| ETS | Extract air sensor | | | | Exhaust air |

Exceptional in every discipline.

The technical data



Distinct design, concentrated power

Despite its many functions, Genius doesn't take up much space. What's more, the appealing design of the unit means it doesn't need to be hidden away in a special service room.

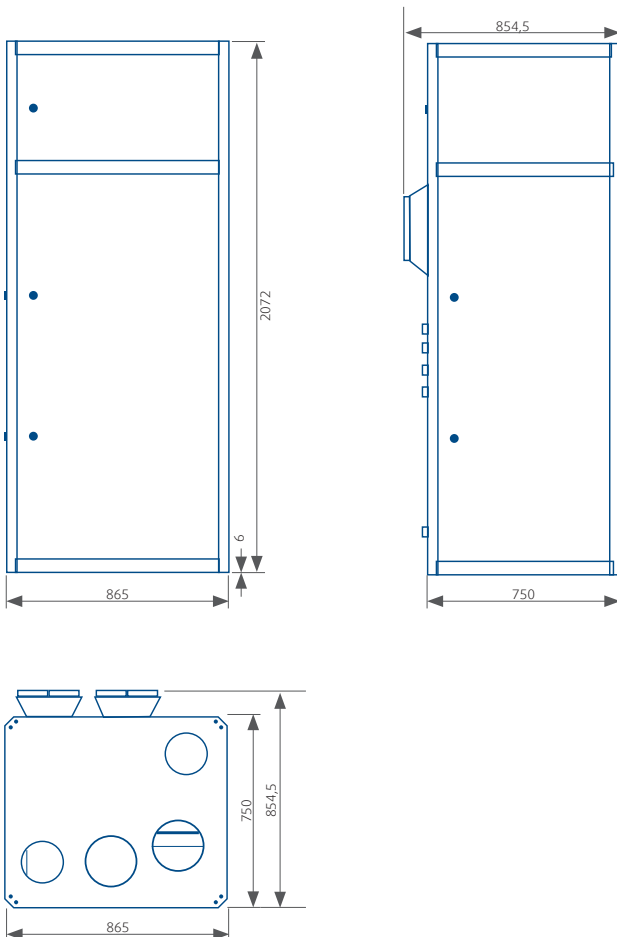

! Products you can rely on



Quality:
Systemair is certified according to ISO 9001, ISO 14001 and ATEX. Our testing and development laboratories are among the most modern facilities in Europe; measurements are taken according to international standards such as AMCA and ISO.



Save energy, reduce operating costs!
Our "Green Ventilations" label identifies all products which are particularly energy-efficient. All products which are marked with "Green Ventilations" unite economy with energy-efficiency.



Prize-winning:
Genius was awarded the Plus X Award in the categories Innovation, High Quality, Functionality and Ecology.



systemair.de/genius

You need more technical information?
Follow the QR code to the Internet.

Air flow/pressure diagram

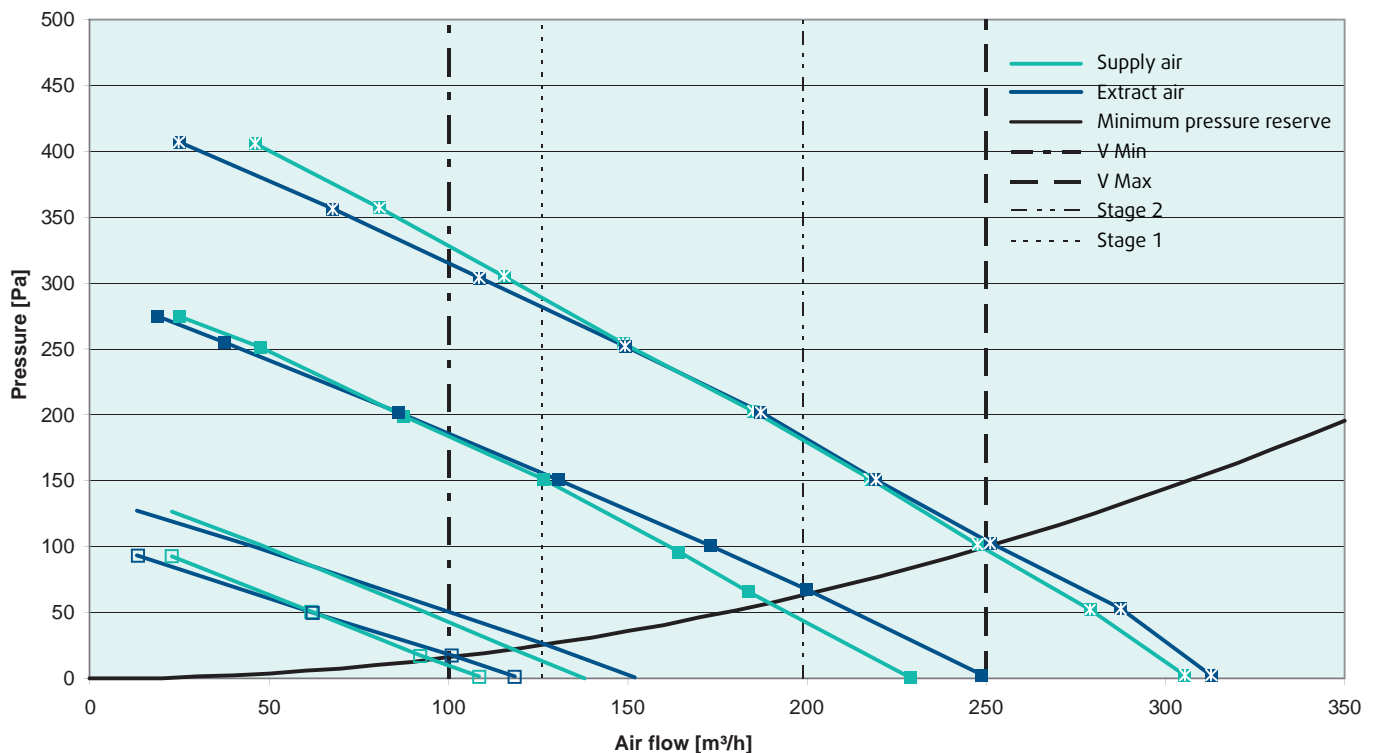

Technical data

Connections

| | | |
|-----------------------------------|----|-------------------------------|
| Cold water | | 1" AG |
| Hot water | | 1" AG |
| Circulation | | 1" AG |
| Condensate | mm | DN 40 hose connection (5 pcs) |
| Safety valve | | 3/4" |
| Outdoor air ventilation | mm | DN 160 |
| Outdoor air heat pump | mm | DN 250 |
| Extract air | mm | DN 160 |
| Supply air | mm | DN 200 |
| Secondary air | mm | DN 200 |
| Exhaust air ventilation/Heat pump | mm | DN 250 |

Performance data

| | | |
|-----------------------|----|----------|
| Max. heating capacity | kW | 6 |
| Max. cooling capacity | kW | 4 |
| PTC element output | W | 500 each |
| Heating rod output WW | kW | 3 |

| | | | |
|--|----------|------|------|
| Setpoint airflow | m³/h | 125 | 190 |
| Heat pump | % | 60 | 60 |
| Temperature outdoor air | °C | -3 | 10 |
| Temperature extract air | °C | 21 | 21 |
| Temperature supply air | °C | 41.8 | 44 |
| Heat recovery efficiency total unit (fictitious) | % | 253 | 399 |
| Performance rating (COP) total unit | | 6.39 | 5.99 |
| Volume related electr. compressor capacity | W/(m³/h) | 4.63 | 4.52 |
| Volume related electr. ventilation capacity | W/(m³/h) | 0.73 | 1.11 |
| Electrical efficiency | | 5.9 | 5.44 |

Electrical data

| | | |
|---|----|----------|
| Voltage | V | 230 |
| Frequency | Hz | 50 |
| Max. compressor power consumption | W | max 1800 |
| Max. fan power consumption Ventilation module | W | each 80 |
| Max. fan power consumption Heat pump module | W | 170 |
| Storage charging pump power consumption | W | 6-28 |

Ventilation

| | | |
|---|------|----------|
| Air flow (normal mode) | m³/h | 190 |
| Max. air flow heating/cooling (incl. secondary air) | m³/h | 600 |
| Outdoor air heat recovery | % | up to 85 |
| Outdoor air filter class | | F7 |
| Extract air filter class | | G4 |
| Secondary air filter class | | G4 |

Dimensions/weights

| | | |
|-----------------------------------|----|------|
| Width | mm | 865 |
| Height | mm | 2070 |
| Depth | mm | 750 |
| Ventilation modul weight | kg | 75 |
| Heat pump modul weight | kg | 60 |
| Basic Modul/hot water unit weight | kg | 170 |
| Total weight when empty | kg | 305 |
| Total weight when full | kg | 460 |

Other

| | | |
|---------------------------|-----|-------|
| Refrigerant | | R410A |
| Refrigerant fill quantity | kg | 1.2 |
| Tank volume | l | 150 |
| Expansion tank | l | 6 |
| Hot water safety valve | bar | 6 |

A well-coordinated team.

The components

The Systemair ventilation system consists of multiple components which are attuned to each other. At the centre of the entire system is the Genius Central Building Services Unit. A duct system distributes the air – consisting of corrugated spiral seam piping or plastic piping with round or oval cross-sections, depending on the requirements.

There is an additional air duct system from the living area to Genius for the secondary air. Furthermore, the supply air ducts must be insulated and, due to the increased air quantities, have larger dimensions than a pure ventilation system.

The supply air manifold requires an outlet for each supply air room. Installed at each of these outlets is a combination of an air damper and a PTC heating element. The damper balances the heating or cooling air quantities. The heating element ensures emergency operation and permits adjustment of the individual room temperature as required. It also provides additional warming of individual rooms.

Individual control units are installed in the supply air rooms. These record the room temperatures and determine the supply air temperature and the heating or cooling requirement for the heat pump. Plastic BOREA valves serve as diffusers. These are suitable for larger air quantities and can be used as supply air or extract air valves. Furthermore, their air distribution pattern can be adjusted for winter and summer operation.

Best of all: Systemair will do all the project engineering for you – from determining the required air quantities and the heating load, to generating the quote and creating the assembly plans





Something you can build on.

Your comfort package from Systemair

With Genius from Systemair, you are getting a top-class central building services unit. In the development of our products we place the highest value on quality, functionality, efficiency and reduced energy consumption. We only use top-quality components from renowned manufacturers. And because we really only want to deliver the best to you and your customers, we will test our new products thoroughly in advance. You can depend on that. Our research and development centres in Sweden and Germany are among the most modern test laboratories for ventilation engineering in Europe.

Expert advice from the start

It goes without saying that such a high quality system comes with appropriate service. This is why we will support you with help and advice during the planning and tendering process. Using the building plans, we determine the required air quantities and the heating load. Subsequently, we configure the entire system for you, using the latest CAD programs and our experience.

So you can be sure that Genius and all its components are ideally attuned to your building. Then we draw up the specifications document and the corresponding prices

We won't let you down during the installation phase either. We offer you comprehensive training courses, we will inform you about the latest technological developments and we will answer all your questions any time you ask. In the assembly phase, we will put together the most precise plans for you and deliver all the system components straight to your construction site. As long as the system is installed according to plan, using our components, we do of course offer a warranty for proper function. If requested, we are happy to support you in the commissioning and adjustment of Genius.

And afterwards, we will still be there for you and your customers. For example, with our filter subscription: Help your customers maintain a healthy room climate and keep energy consumption down. We are happy to deliver new filters for the system, regularly and automatically.

Our all-round worry-free service makes it easy for you.



The comfort package

- **Determination of air quantities and heating load**
- **Configuration of the system**
- **Quote generation**
- **Creation of assembly plans**
- **Delivery of the components to the building site**
- **Support during assembly, commissioning and maintenance**



Sven Haustein, haalplatz architekten, Schwäbisch Hall, Germany

„For years now we have been planning high-quality, airtight houses. They are very well-insulated with the best components and very low energy consumption. But due to the lack of alternatives for building services, until now we have always had to use expensive elements which were mostly over-dimensioned for the specific requirements, or were to a certain extent unnecessary. The Genius combi-unit is exactly the alternative that we needed.“

Often asked. Happily answered.

Our customers' FAQs

What is the difference between secondary air and recirculating air?

Recirculating air is extract air which is treated and then fed back as a component of the supply air to at least one room from which it was not originally taken. This means it is possible for odours and substances to be transmitted. In contrast, secondary air is removed from a supply air zone, fed through a separate duct system and, after treatment, is fed back into the same room.

Mixing with the extract air is therefore excluded. This also applies to the Genius system. The only difference is that the secondary air is fed back into the entire supply system after treatment, not to one room.

For what buildings is Genius appropriate?

The application limits are:

≤ KfW 55: max. 190 m² living area

KfW 70: max. 150 m² living area

What other basic requirements must be met?

- The supply air duct system must be designed for the higher flow rates and must be insulated
- A separate duct system is required for the secondary air.
- Additional electric convectors or underfloor heating is recommended in bathrooms

Is the Domestic Hot water tank sufficient to supply a one-family household without additional electrical energy?

With Genius, the hot water is produced on demand and is possible during all operating states, i.e. also during heating and cooling. The domestic hot water tank holds 150 litres. Thanks to the parallel operation and

the performance of the heat pump, this is sufficient for a one-family household, even with a high level of consumption. The additional electrical heating element only has the following functions: Legionella control program, fast charge, emergency operation and assistance when the outside temperatures are extremely low.

Can Genius be operated in combination with a fireplace?

Yes, as long as the fireplace is installed independently of the ambient air. This is because if an ambient air-dependent fireplace is operated in parallel to a ventilation system, the possibility must be ruled out that, if an underpressure forms, exhaust gases from the fireplace enter the room. Here, safety measures are required which could result in the system being switched off. Since Genius also provides the entire heating function, any shutdown must be prevented.

The heat from an ambient air-independent stove operated in parallel can be simply and evenly distributed throughout the whole house via the Genius secondary air duct system.

How can the temperature be regulated in individual rooms?

With an air heating system, you can control the temperature of a single room using the PTC reheating elements. Here the heat pump only supplies the temperature which is demanded by the room controller with the lowest setpoint temperature (this is generally in the bedroom). The temperature increase in the other rooms is provided individually by the electrical reheating elements

