

Contents:	Page:
Notes on these installation instructions	1
Safety precautions	1
Possible installing positions, technical specifications, waste disposal	2
Dimensional drawings	3-5
Installation examples	6-7
Parts supplied	8-9
Installation: Housing and electrical connection	10-12
Installation: Ventilator insert and decor plate	13
Electrical connection, wiring diagrams	14-15
Run-out setting	16
Filter change, cleaning	16
Accessory and replacement parts	16

Notes on these instructions

- Read these instructions carefully and completely prior to starting installation! The general safety precautions and safety symbols with notes in the text must be observed
- When installation has been completed, pass these directions on to the user (renter, owner, block manager or other)

Symbols in these directions:



This symbol warns on danger of injury



This symbol warns on danger of injury by electricity

Safety precautions



Danger! Assembly work is only to be carried out on the ventilator when it is separated from the line voltage! The ventilator is protectively insulated to protective class II, the protective conductor connection is not needed!



Caution! Electrical connection is only to be made by authorised skilled personnel and under observance of current VDE 0100 regulations of the German Electrical Engineering Association!



Caution! This piece of equipment is not to be operated (filter change, cleaning) by children or persons who cannot operate it properly because of their physical, sensorial or mental ability, or their inexperience or lack of appropriate knowledge



Ventilators involved in off-air exhaust must always be supplied with a functioning flow-in of outside air.

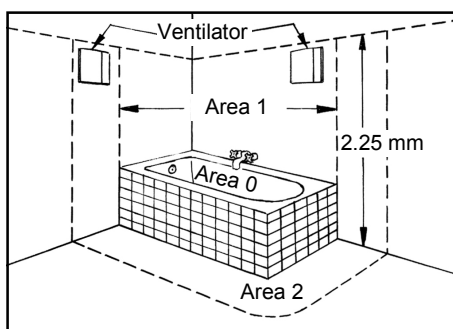

The German VDE 100 regulation permits installation in bath and shower room area 1

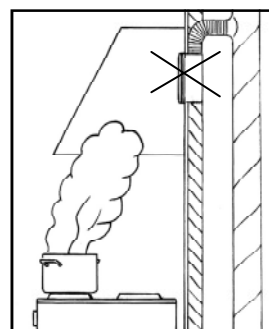

Ventilator installation as extractor hood is not permitted here

Possible installation position for duct fitting

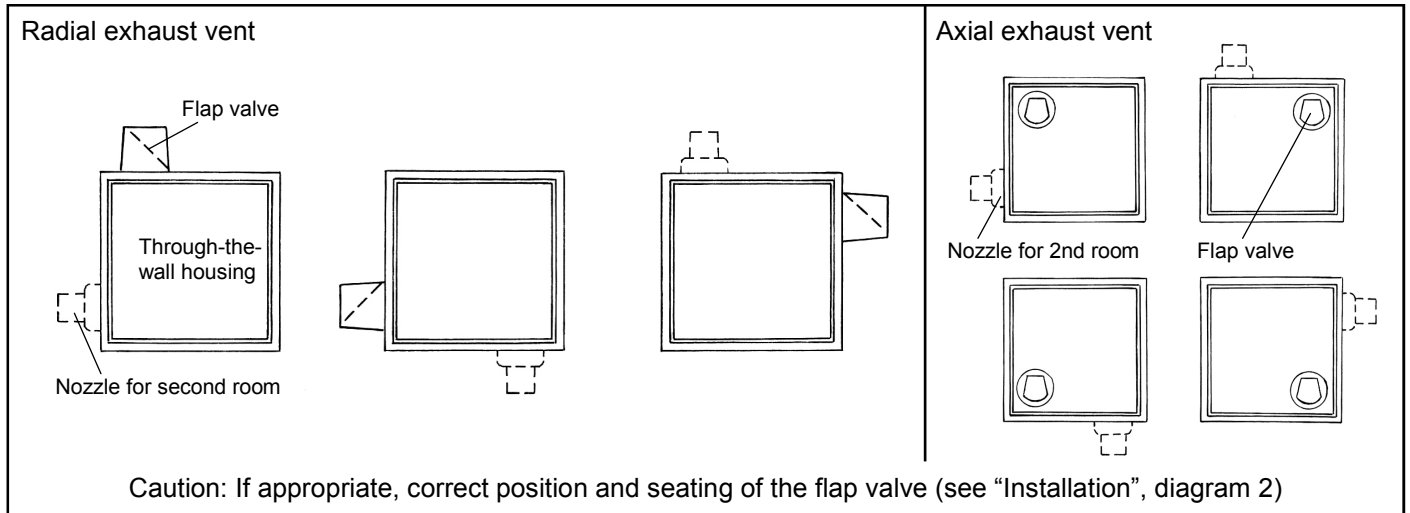

Technical specifications

Electrical connections

Voltage supply:	230 V AC 50 Hz
Control voltage (ventilator type ... FK):	12 V DC
Protection class:	II
Protection type:	IP X4
Admissible for use in area 1 of wet rooms	

General

Silvento type	Volume flow	Power consumption	Sound-pressure	Run-out time	Interval	Inverse operation	Movement sensor	Humidity control range
V ¹⁾ or KL ²⁾	[m³/h]	[W]	[dB(A)]	[min.]	[h]			[% rh]
30/60/100	30/60/100	4.9/10.5/36.5	24/35/44					
30/60B	30/60	4.9/10.5	24/35				yes	
30/60ZII	30/60	4.9/10.5	24/35	6/ 15 ³⁾	4	yes		
30/60BZII	30/60	4.9/10.5	24/35	6/ 15 ³⁾	4	yes	yes	
60ZII	60	10.5	35	6/ 15 ³⁾	4	yes		
60BZII	60	10.5	35	6/ 15 ³⁾	4	yes	yes	
30/100ZII	30/100	4.9/36.5	35/44	6/ 15 ³⁾	4	yes		
30/100BZII	30/100	4.9/36.5	35/44	6/ 15 ³⁾	4	yes	yes	
100ZII	100	36.5	44	6/ 15 ³⁾	4	yes		
100BZII	100	36.5	44	6/ 15 ³⁾	4	yes	yes	
30-60 FK	30/40/50/60	5.3/7.2/8.9/10.9	24/27/32/35					50 - 70

Footnotes: 1) Silvento V units are ventilator inserts that additionally require either a concealed housing or surface-mount housing.

2) Silvento KL units are complete single pipe ventilators that are clamped in the curtain wall construction. Silvento KL single pipe ventilators fit in concealed housings of LUNOS Skalar versions.

3) The updated DIN 18017-3 requires the removal of a further 15 m³ air over the ventilation system after switching off the fan.

4) 30 min run-out time

All ventilators are equipped with a Class G2 (EN 779) filter and a filter change display.

Ventilators of the "Silvento" series fulfil all requirements:

- of DIN 18017-3; Allgemeine Bauaufsichtliche Zulassung Z-51.1-215
- for low voltage (CE) acc. to EC Directives (2006/95/EG)
- for electromagnetic compatibility (CE) acc. to EC Directives (2004/108/EG)

Waste disposal



Sort the packaging for appropriate disposal. Observe current requirements should you want to dispose of the ventilator. Within the framework of the Electrical and Electronic Device Act (ElektroG), the return of this device free of charge is guaranteed at your local turn-in center.

Dimensional drawings:

Plastic housing (radial exhaust) (Housing type 3/UP-R)

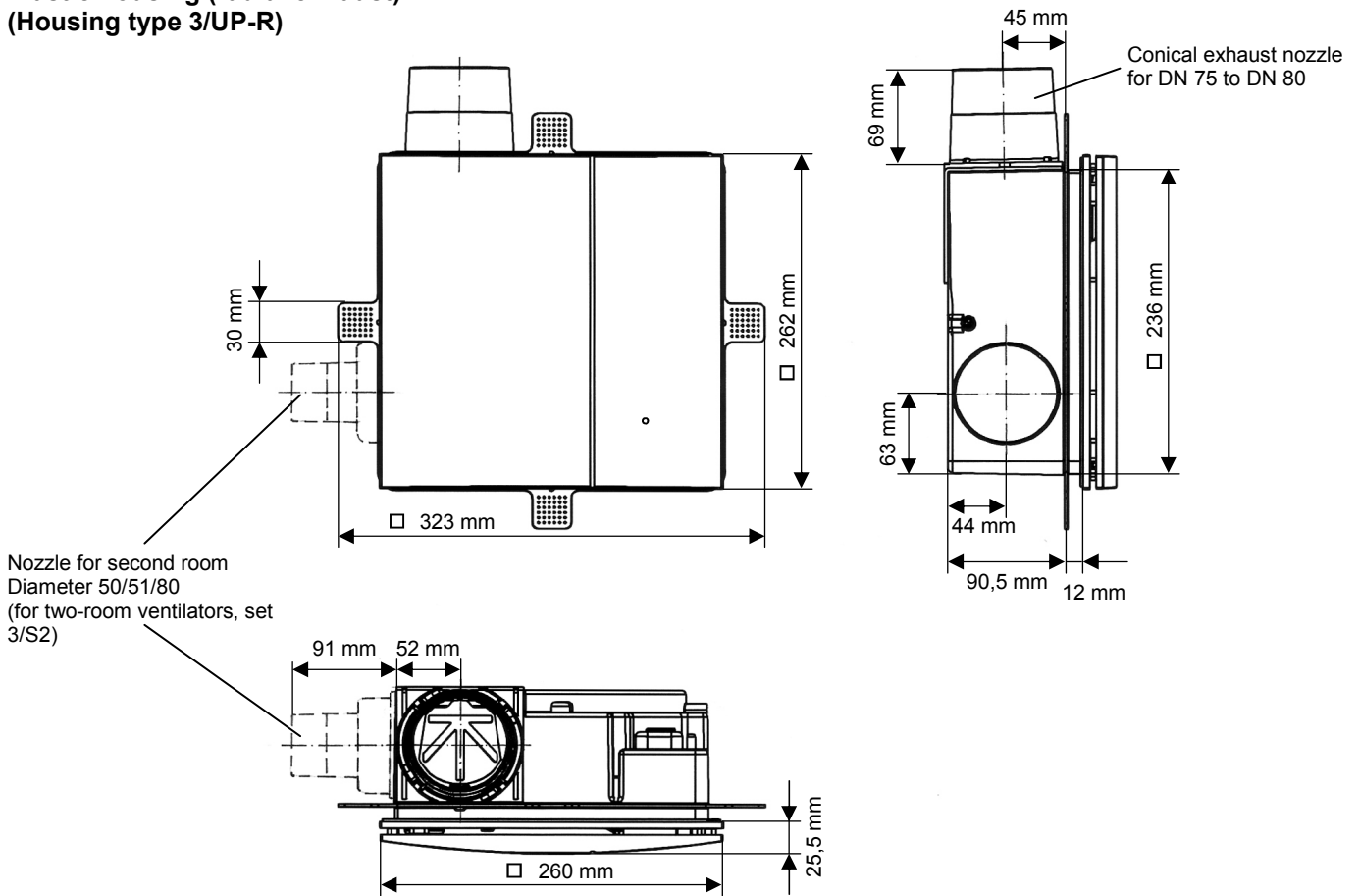

Plastic housing (axial exhaust) (Housing type 3/UP-A)

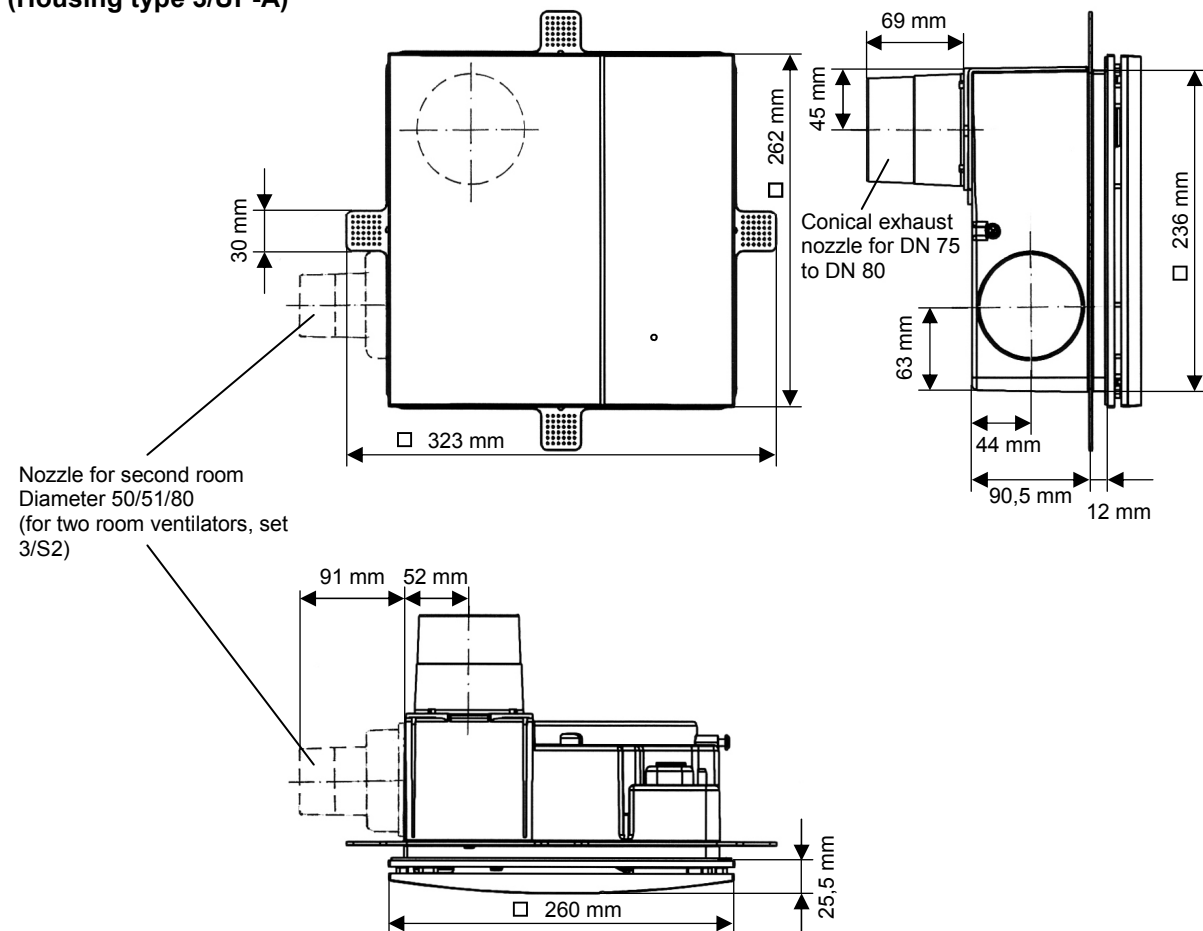

**1 Room with kitchen fire protection (radial exhaust)
(Housing type 3/UP-BR)**

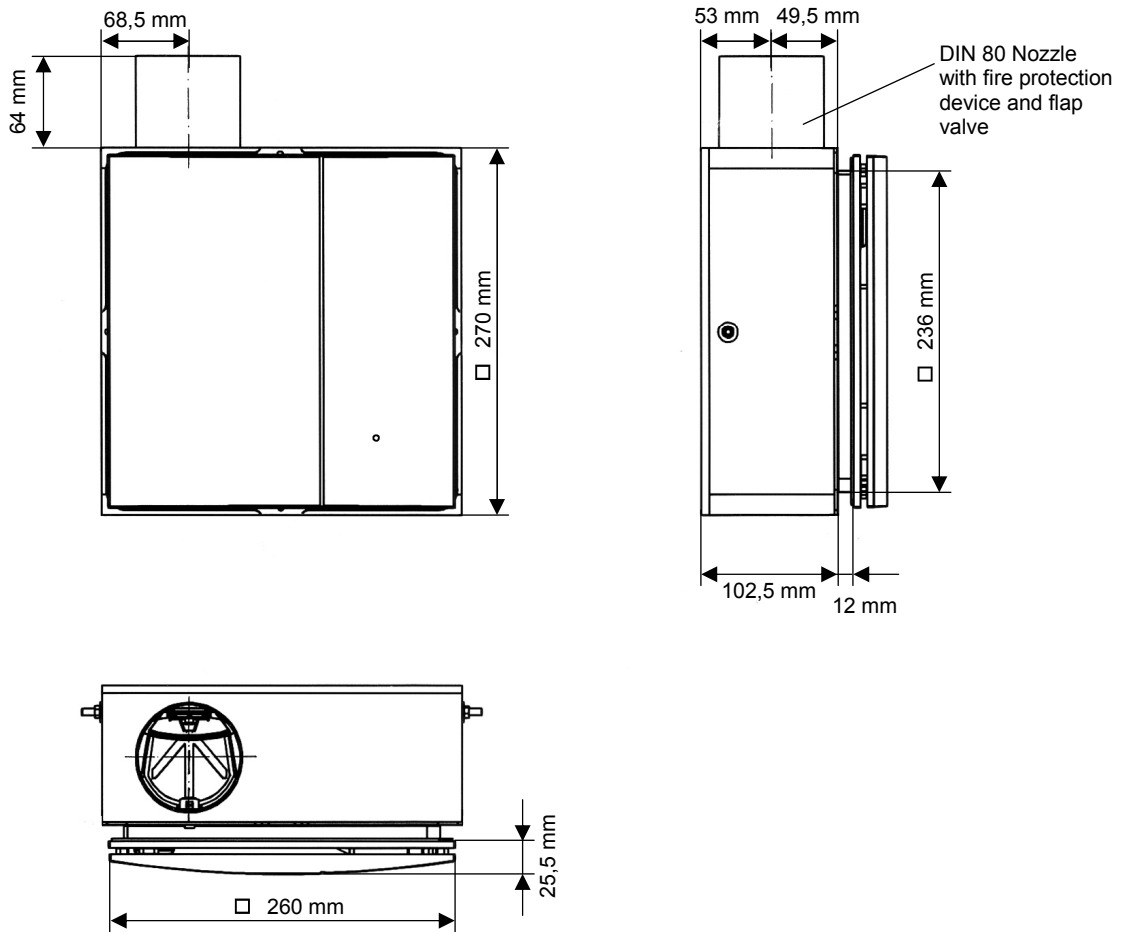

**1 Room with kitchen fire protection (axial exhaust)
(Housing type 3/UP-BR)**

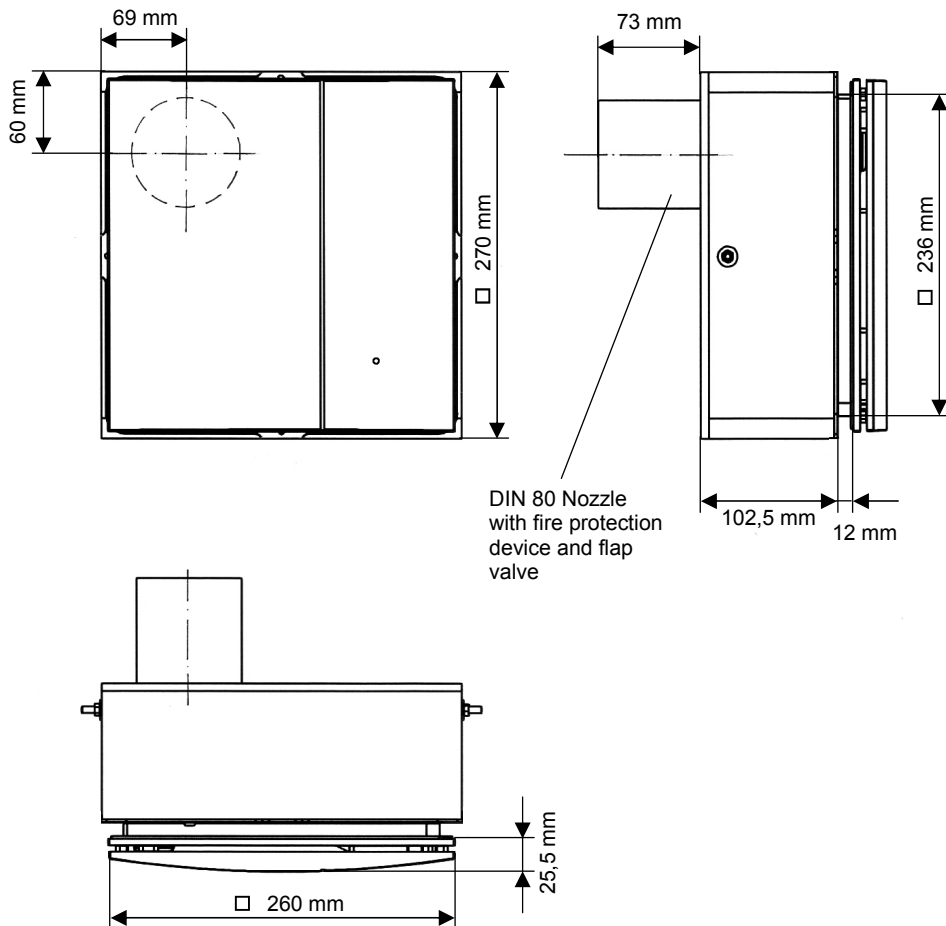

**2-Room with kitchen fire protection (radial exhaust)
(Housing type 3/UP-2BR)**

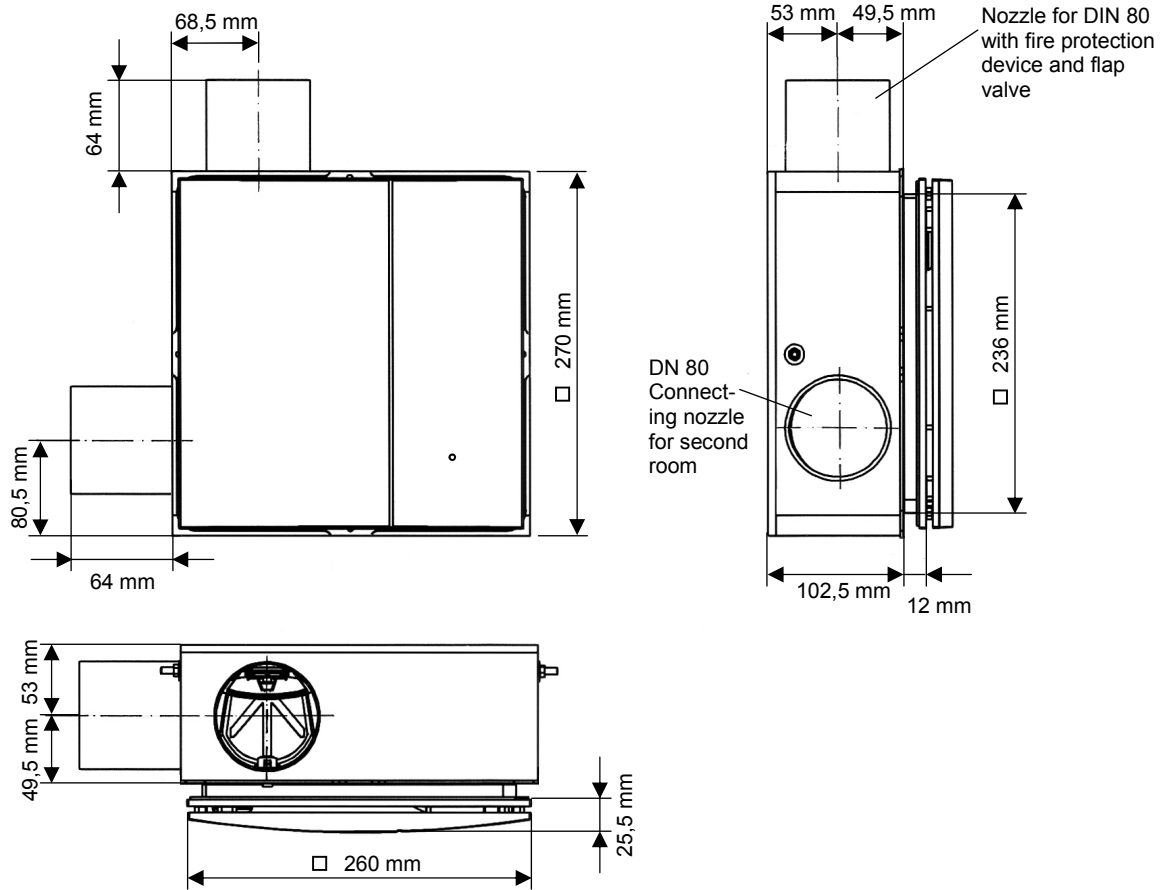

**2-Room with kitchen fire protection (radial exhaust)
(Housing type 3/UP-2BA)**

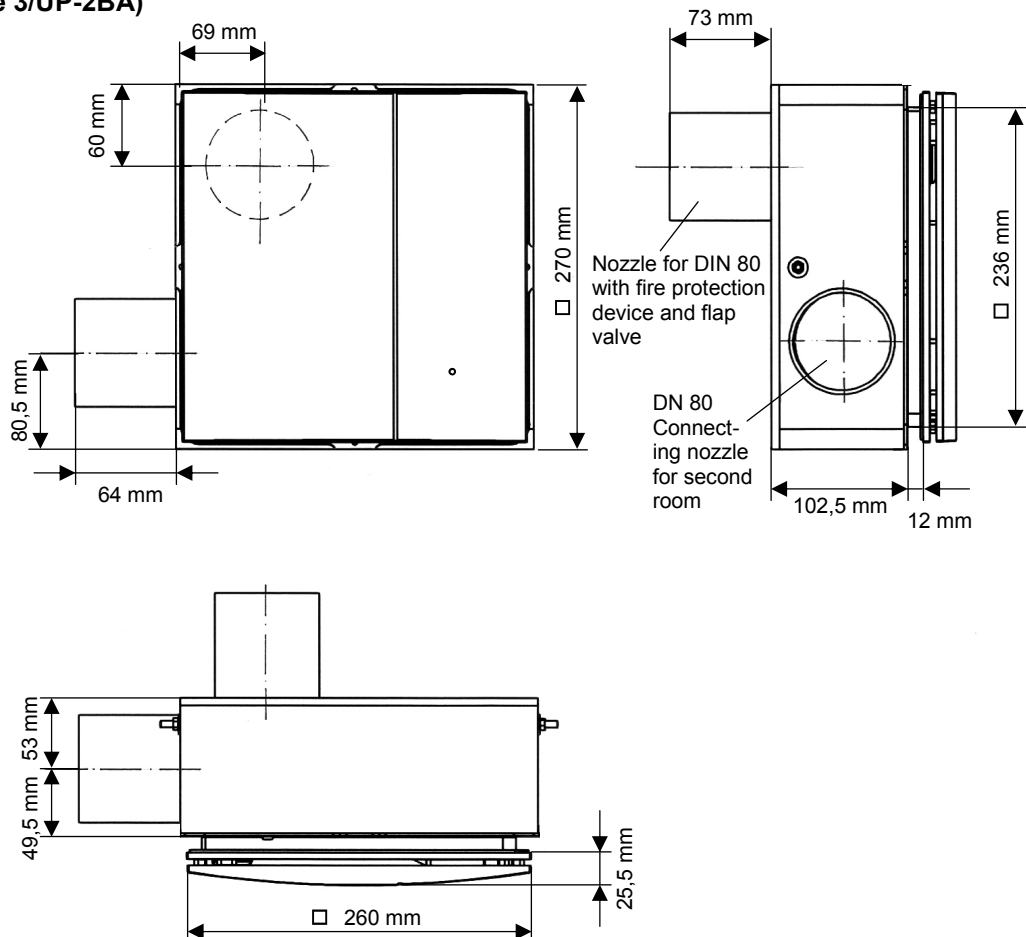

Installation examples

One room ventilator: Duct installation

Duct installation without fire protection

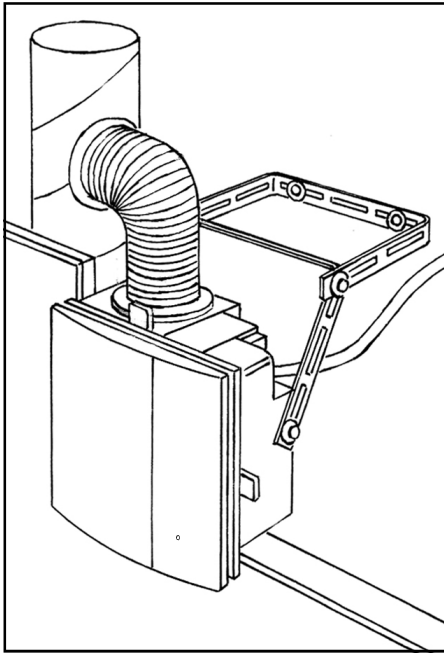

Duct installation with fire protection

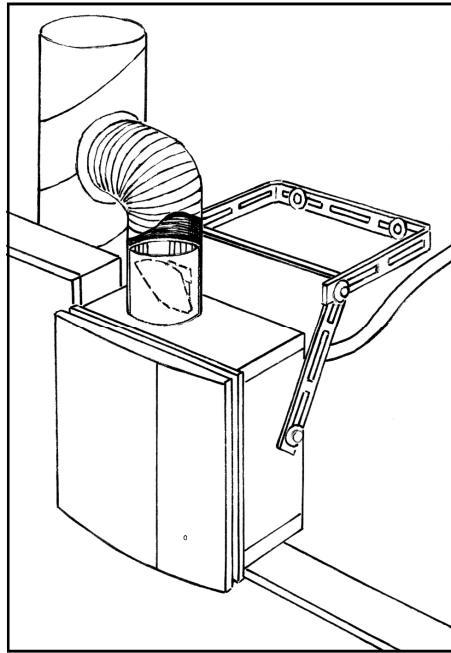

Exterior wall installation

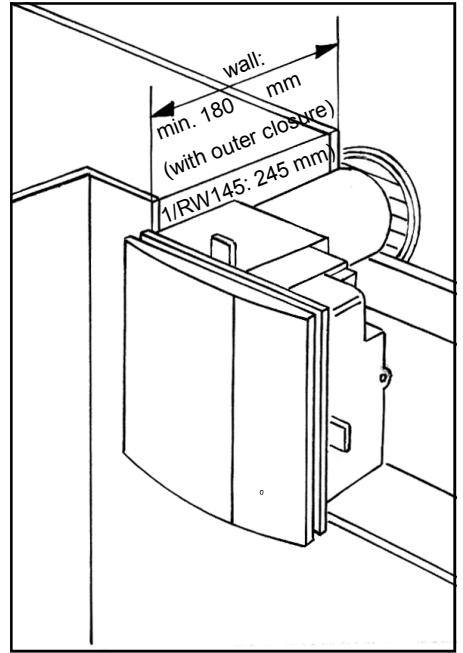

One room ventilator: Ceiling installation

Ceiling installation without fire protection

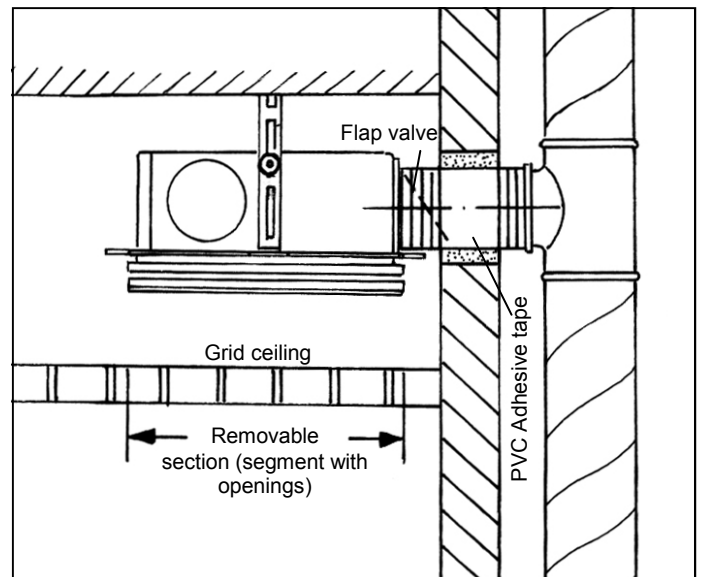

Ceiling installation with fire protection

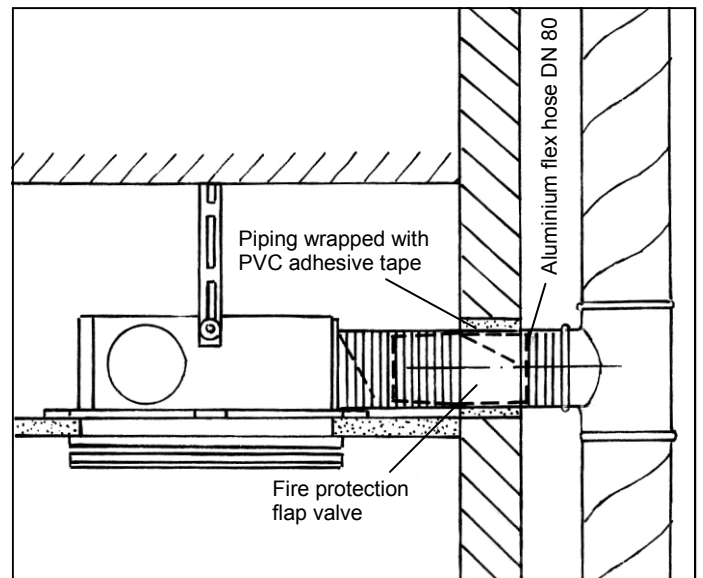

2 Room ventilator: Duct installation

Duct installation without fire protection

Note:

All installation examples shown are possible both with radial (“exhaust upwards”) and axial (“exhaust behind”) exhaust openings and can be selected according to the purpose.

When with fire protection, the duct wall must be fire resistant for the required period.

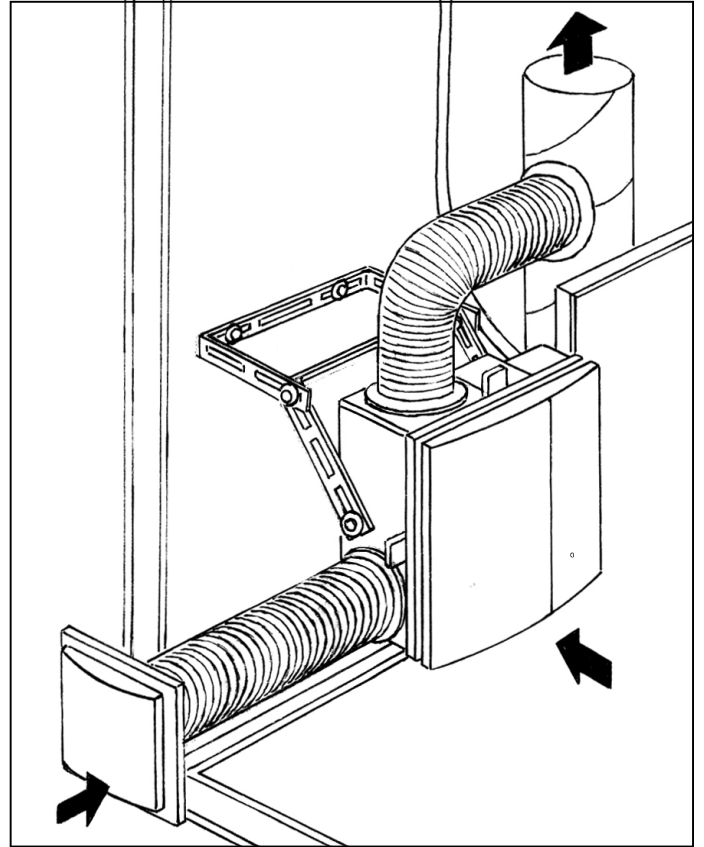

2 Room ventilator: Ceiling installation

Ceiling installation without fire protection

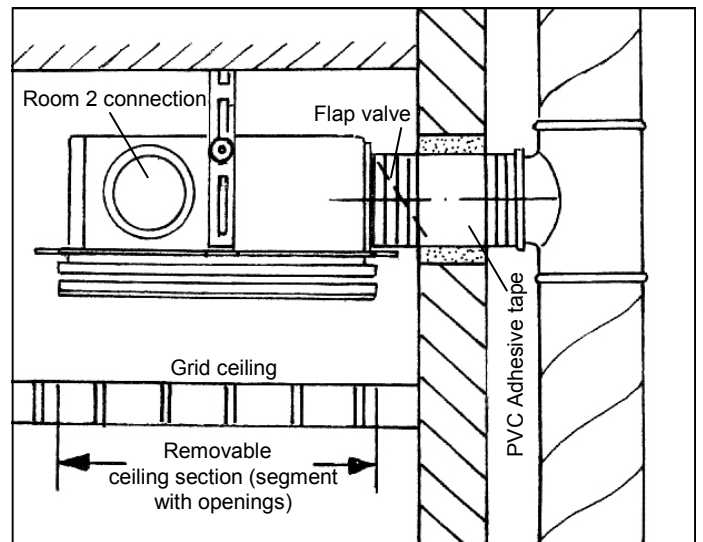

Ceiling installation with kitchen fire protection

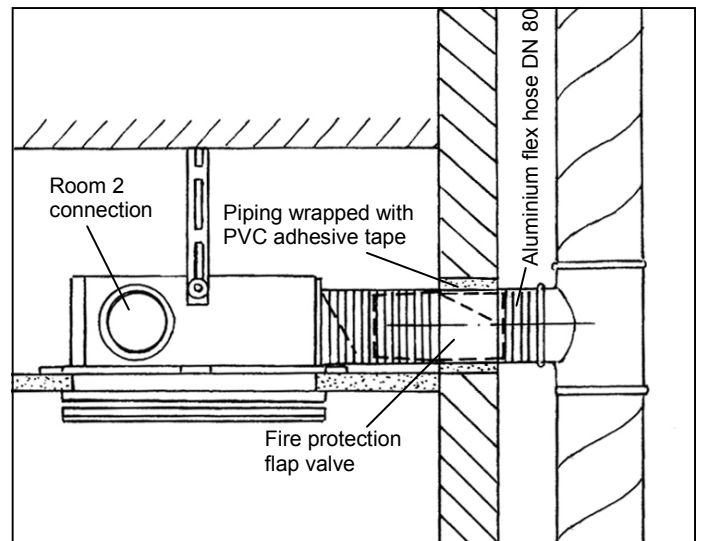

① Wall installation housing (variant)

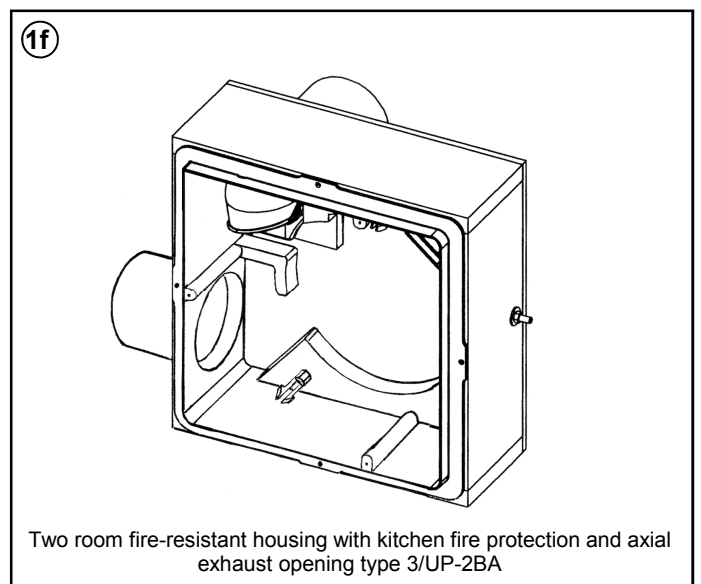
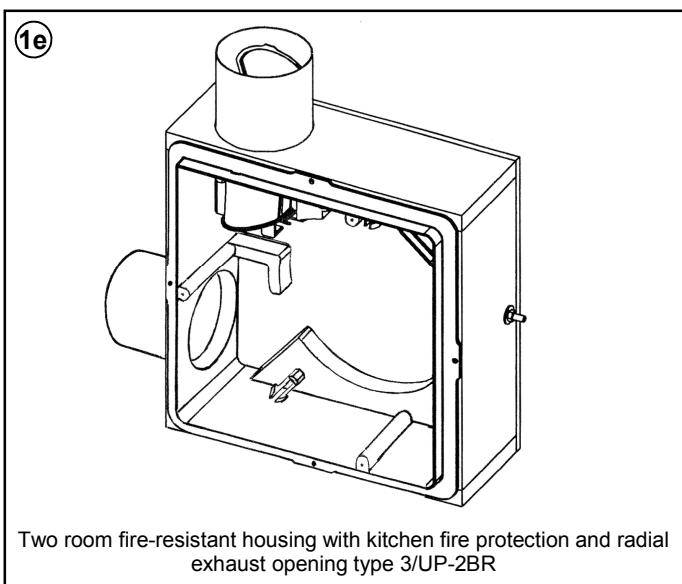
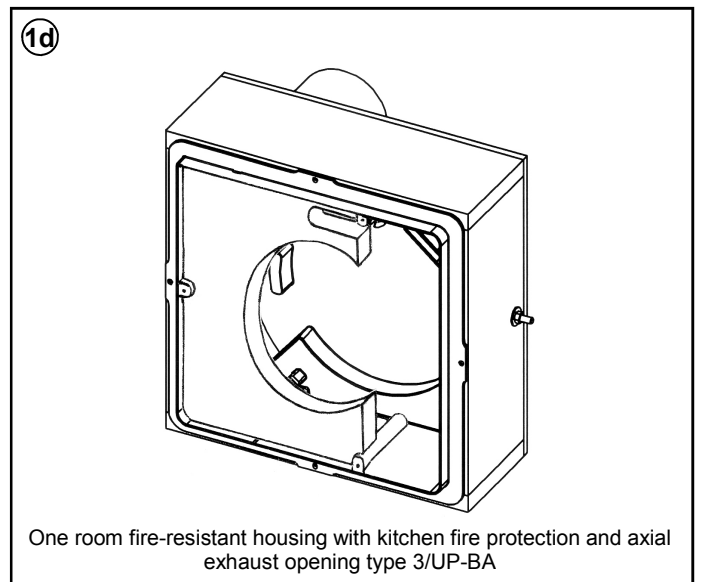
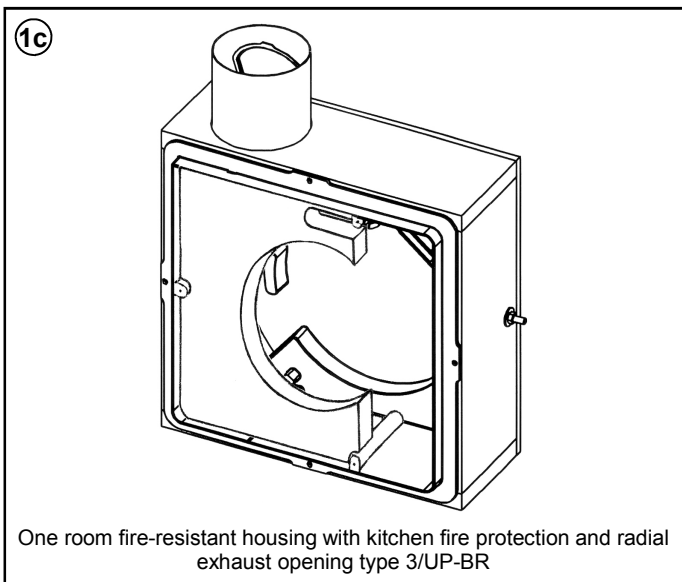
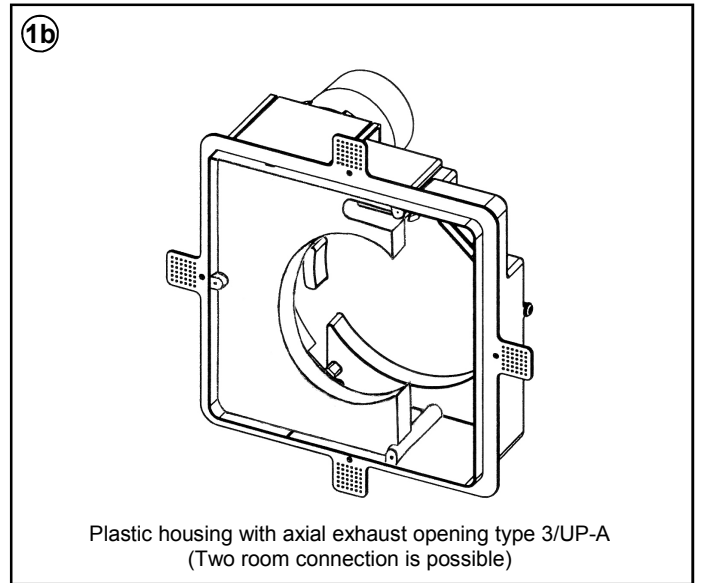
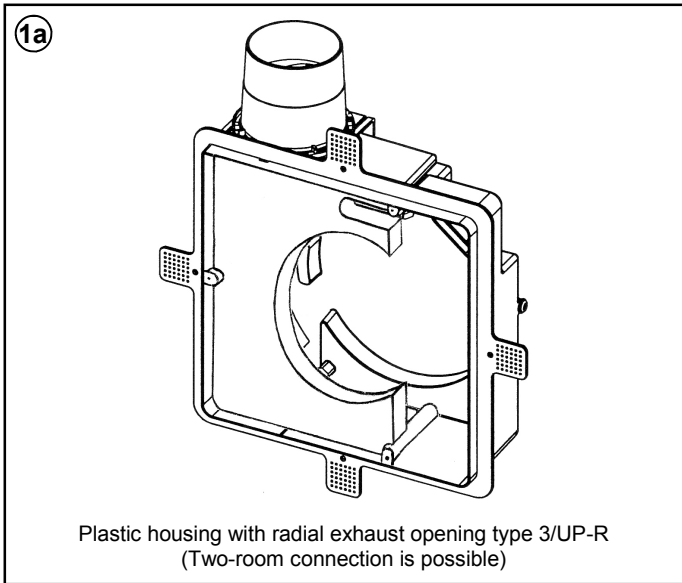

All through-the-wall housings include:

- Flap valve
- Power supply terminal
- Plaster protective cover

- Mounting bracket with screw

② Ventilator insert Silvento V ...

Ventilator insert

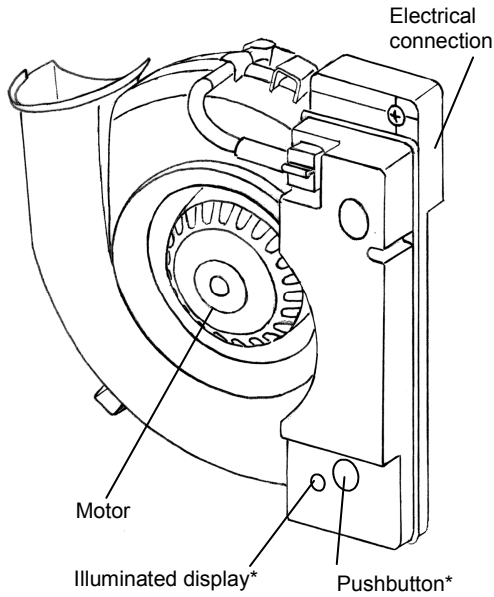

* Illuminated display and pushbutton are located in the grid cover frame in case of fans with motion detector

Decor plate

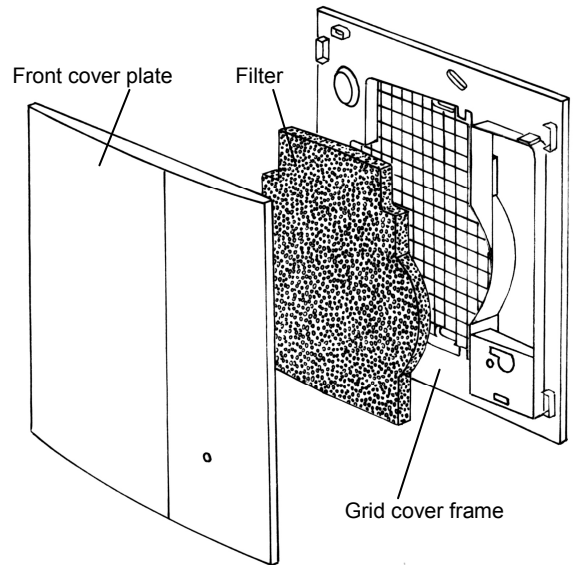

+ Screw accessories

③ Two room accessories

2 Room set 3/S2

Two room wall closure 2/ZSKA

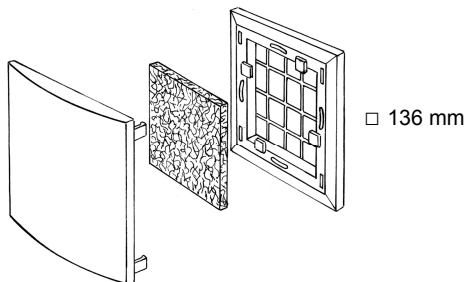

Connecting nozzle DN 80 2/STU

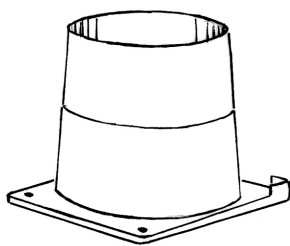

Orifice plate for two room ventilator

Two room nozzle (fits plastic housing)

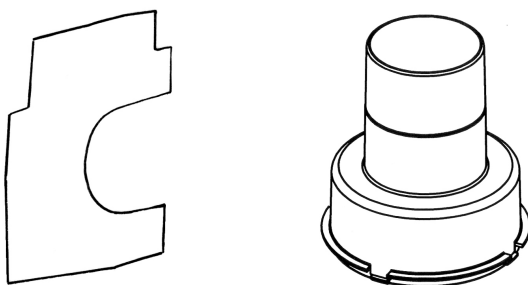

Fire protection - 2 Room set 8/B2

Two room wall closure 2/ZSKA

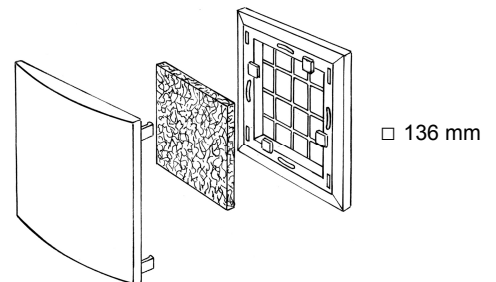

Fire protection nozzle type 8/BS (fits on 2/ZSKA)

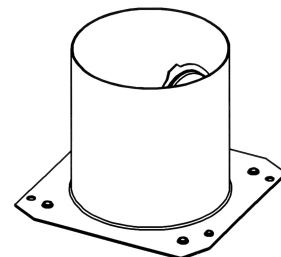

Orifice plate for two room ventilator



Installation - Housing and electrical connection (Is not applicable to all housing variants in the main)

Note: Remove the plaster protecting cover for installation steps ① to ⑧ .

With two room systems with plastic housing:

- Remove the sound insulation (is not used with two room systems)
- Break out the two room opening and mount the two room nozzle

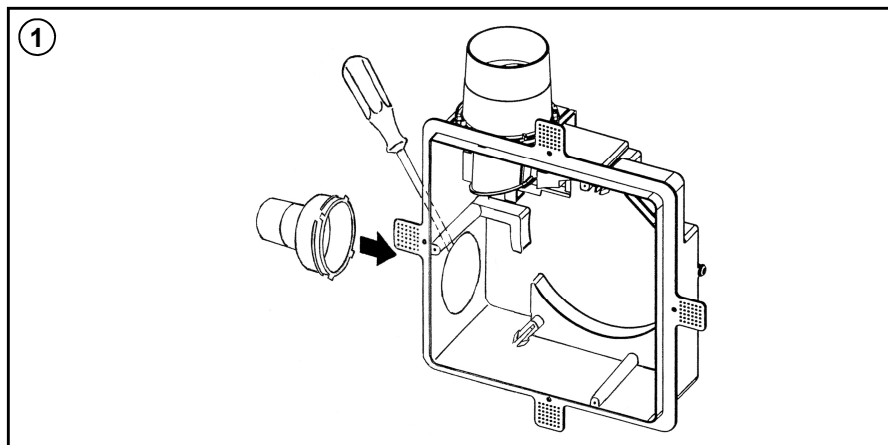

Check the flap valve position relative to the selected installation position (see p. 4):

For correction:

- **With plastic housings:** Turn the nozzle with flap valve to disengage it, lock it back in the correct position.
- **With fire protected housings:** Screw off the insert with flap valve, turn it, then screw it back on.

Replace the sound insulation!

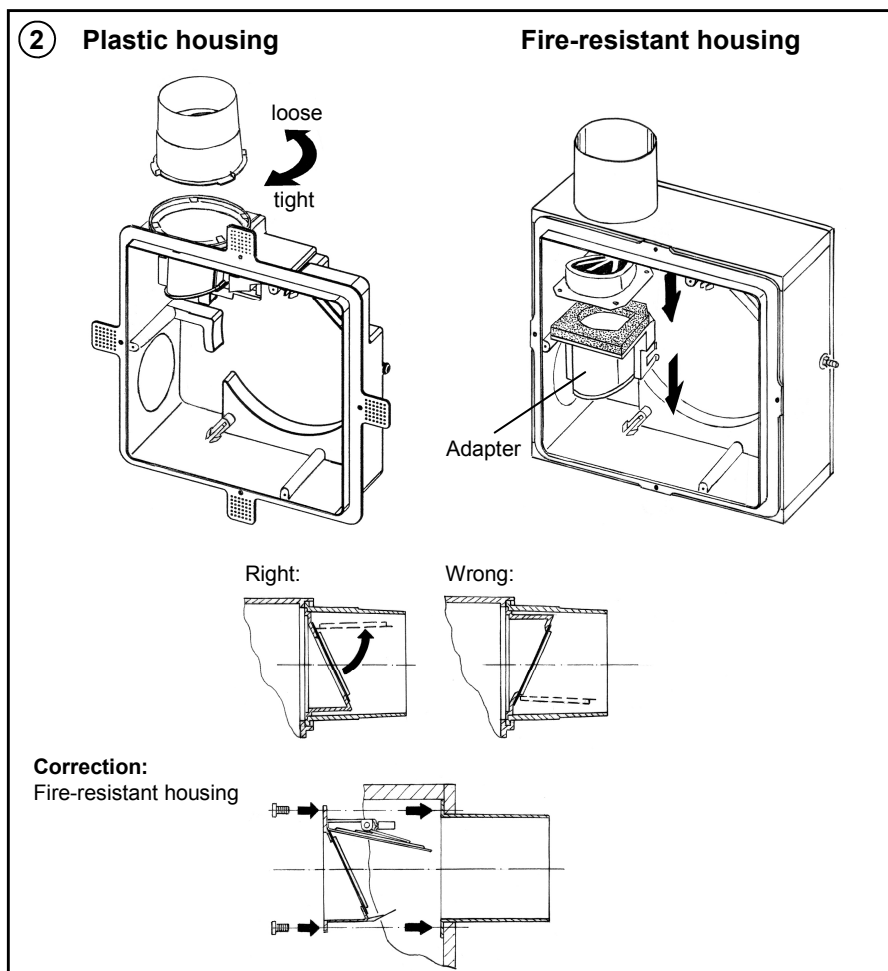

Mount the assembly bracket to the housing using the screw accessories.

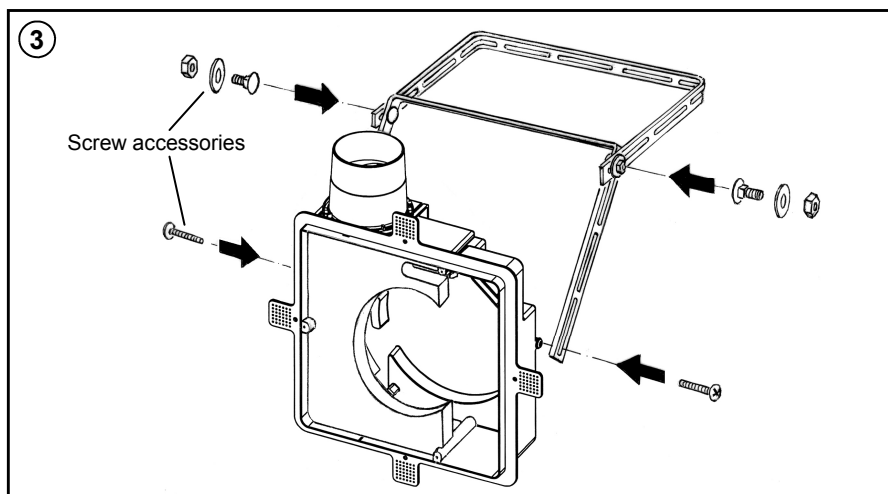

Fix the housing to the duct wall using the mounting bracket

(screw accessories are not standardly supplied)

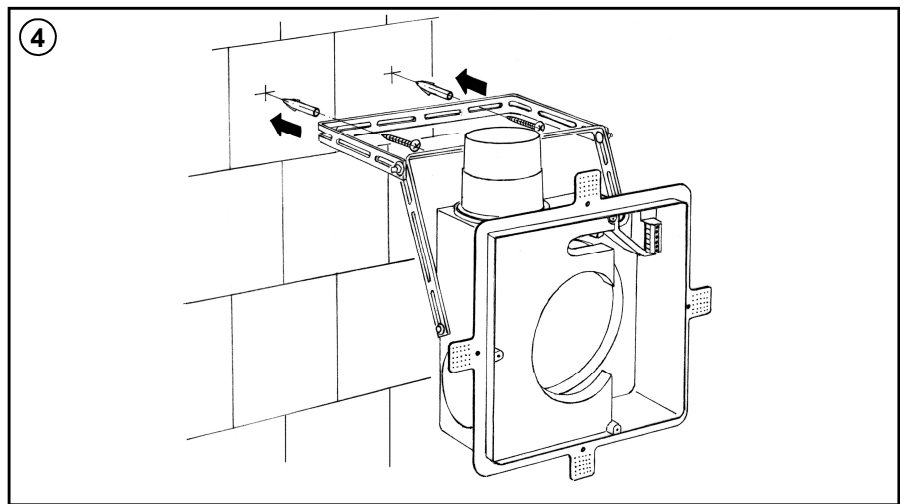

Connect the flex tube:

- Seal the connections flex tube-main piping and flex tube-nozzle with sealing tape or pipe clamps
- Flex tube for room 2

- Wrap the piping in wall breakthrough area with PVC adhesive tape
- Allow the tube end to overhang by approx. 10 cm to protect against penetrating dirt
- Completely mortar the flex tube in

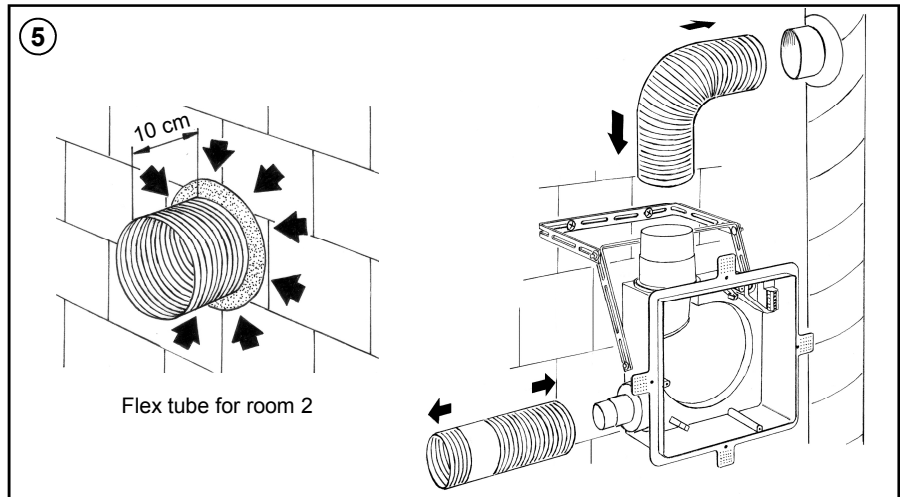

Open the cable grommet (cut off) and lead the cable through

Ensure water tightness, see Fig. 7

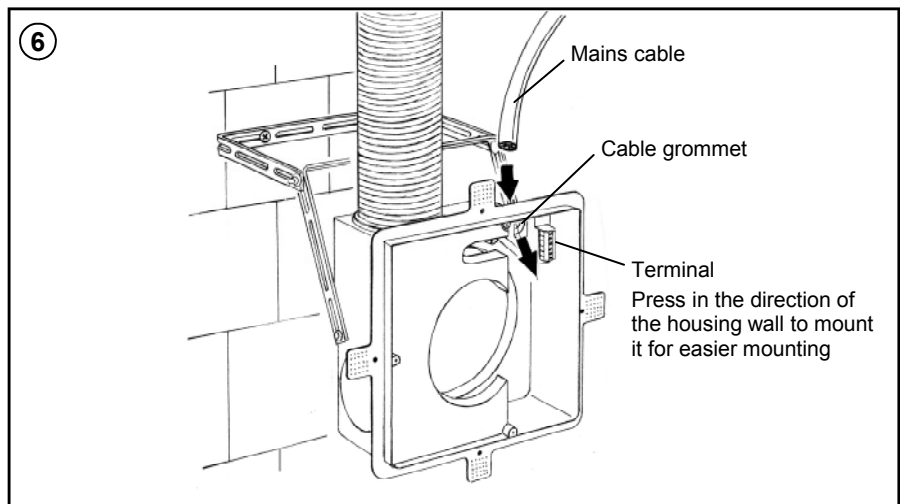

Mains connection:

- Strip the mains cable as shown
- Mount the power supply terminal according to the selected connecting diagram (see connecting diagrams). For easier mounting, the terminal can be removed by a press in the direction of the housing

Caution! The mains cable must be dead!

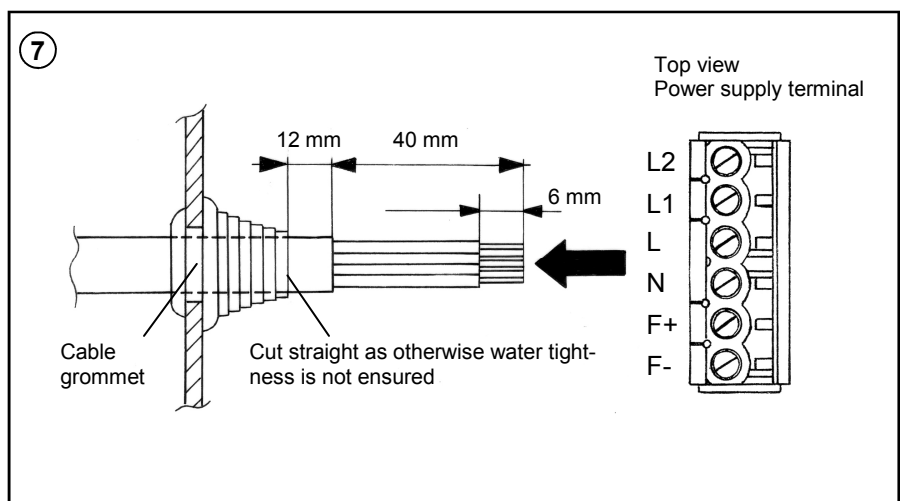

Lock the terminal in position:

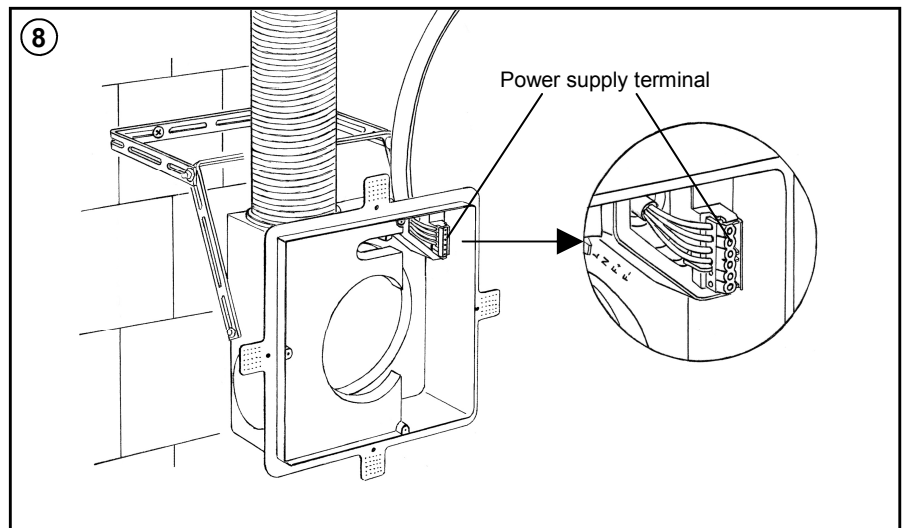

For simple mounting of plastic housings to light-weight walls use the four mounting elements at the rim of the housing:

- Take the plaster protecting cover off
- Remove the sound insulation
- Position the housing in the wall frame section from the inside and fix with drywall screws
- Replace the sound insulation
- Put the plaster protecting cover back on
- Plaster in

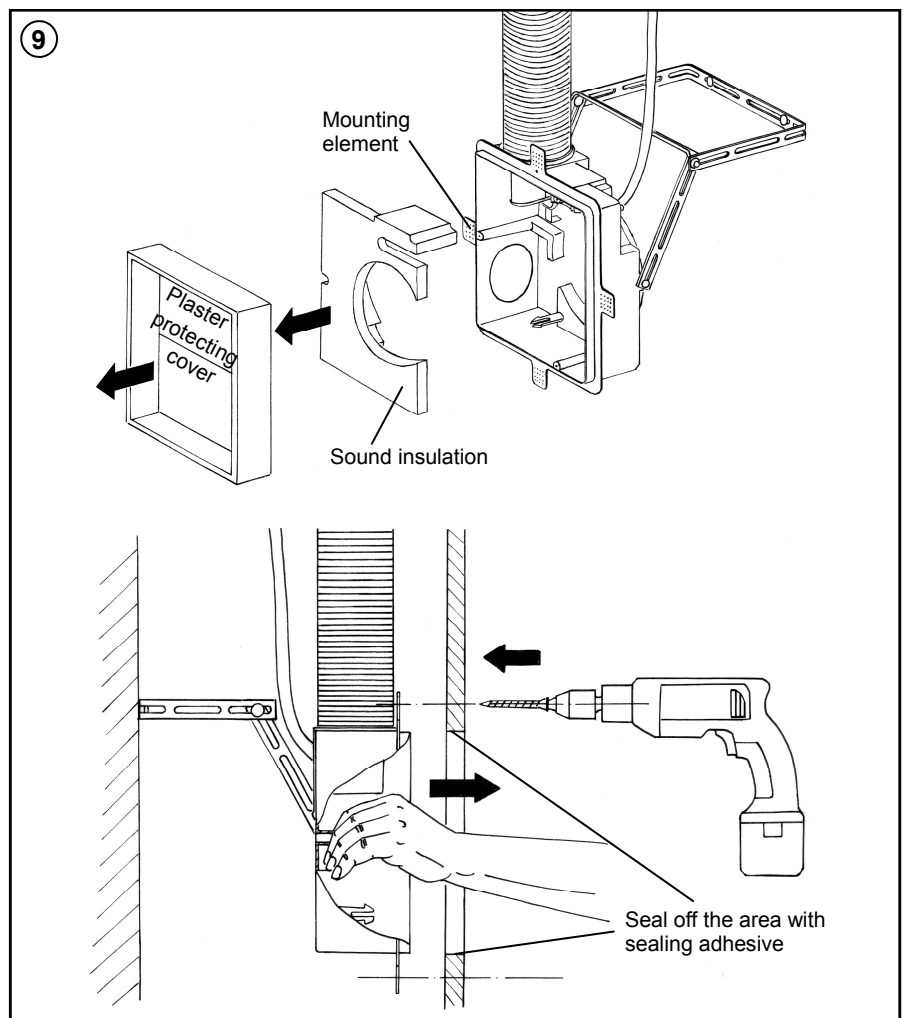

Put the plaster protecting cover back on:

If appropriate, pinch off the securing elements (see Fig. 9a)

- Plaster in! Leaks lead to losses in air volume flow
- Firm seating of the installed housing is first reached through duct wall and plaster

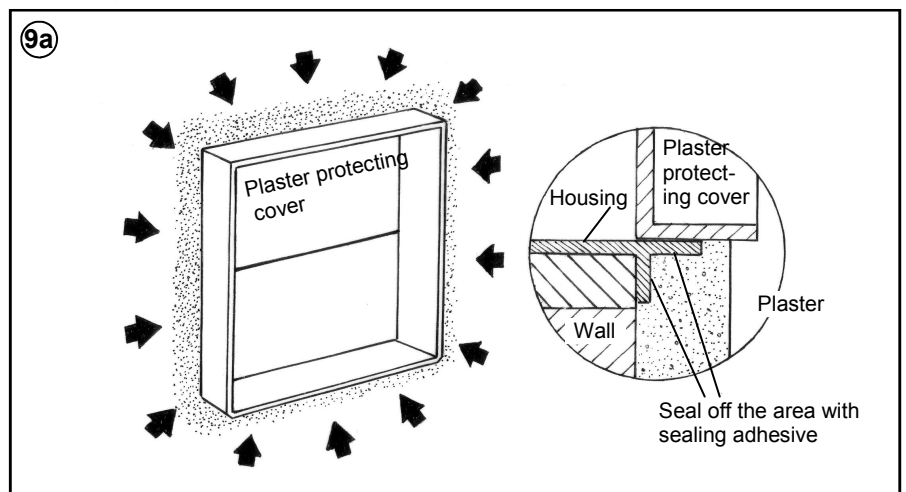

Installation - Ventilator insert and decor plate

Ventilator insert mounting:

- Take the plaster protecting cover off
- Remove the sound insulation
- Tightly lock in the ventilator insert and screw on the power supply area
- Replace the sound insulation (except for two room systems)

Caution: Do not operate one room ventilators without sound insulation.

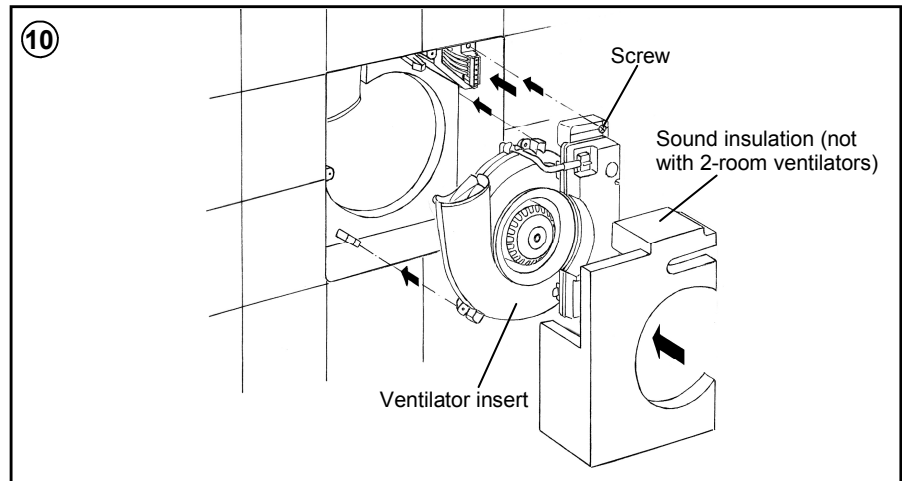

Decor plate mounting:

- Free up bolt openings in grid cover frame (marked with "UP")
- Use the screws supplied to fasten the grid cover frame to the ventilator housing
- Put on the front cover plate and lock it

With two room ventilators:

- Lay the orifice plate under the filter in the grid cover frame (there is no sound insulation in two room systems)

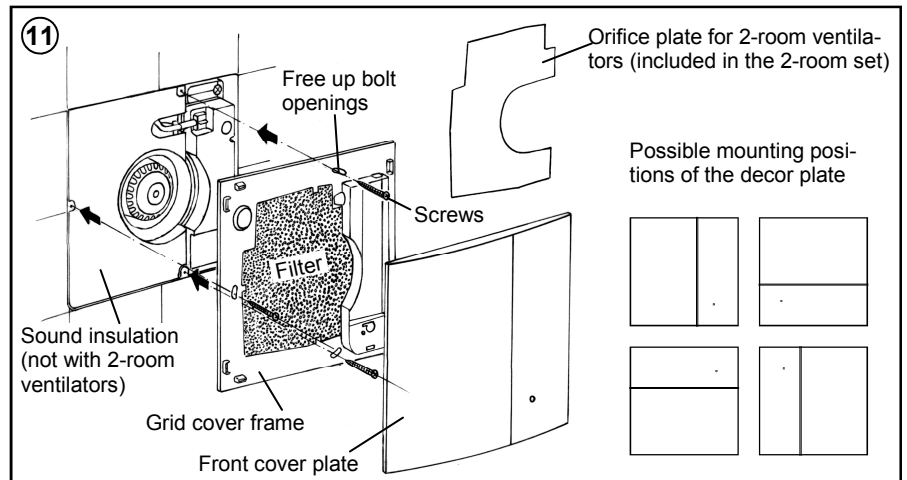

Two room connection without fire protection:

- Use the drilling template in the accompanying 2-room set
- Previously shorten overhanging flex tube by cutting flush with the wall

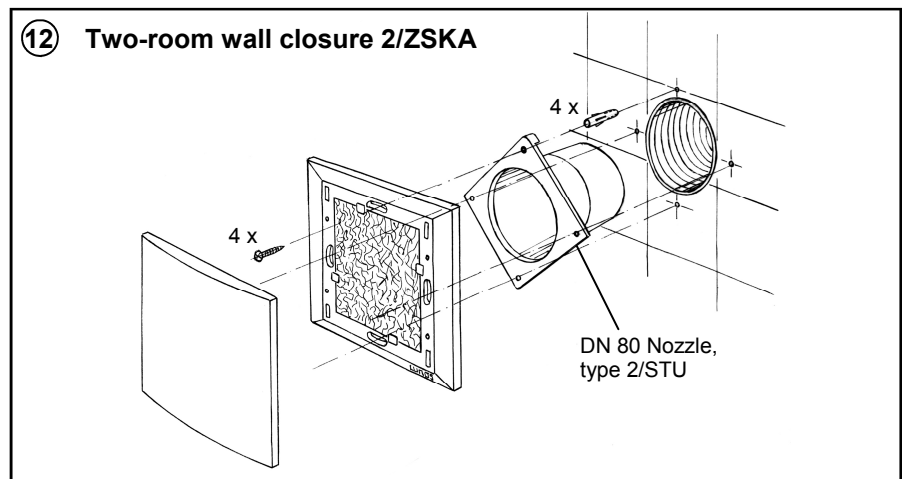



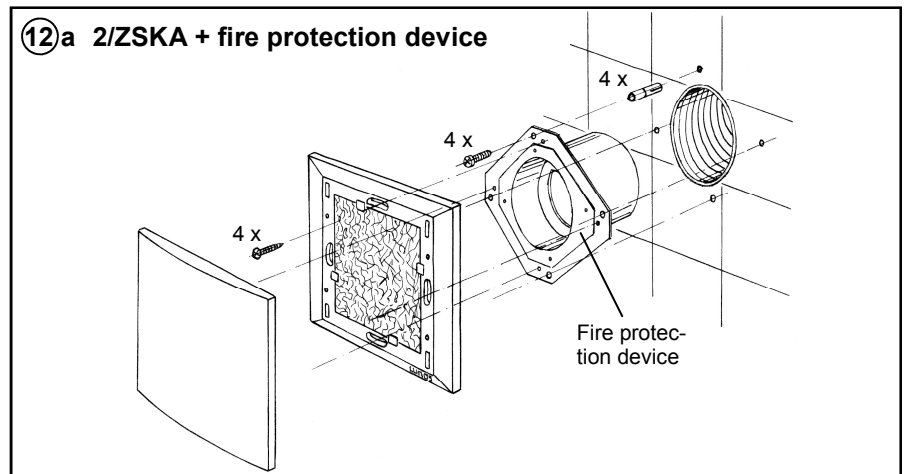

Two room connection with fire protection:

- Use the drilling template in the accompanying 2-room set
- Previously shorten overhanging flex tube by cutting flush with the wall



Electrical connections - Wiring diagrams

Safety precautions:

-  Caution! Only carry out ventilator installation work when the ventilator is separated from the mains voltage! The ventilator is protectively insulated according to protective class II, the protective conductor protection is not needed.
-  Ensure that all connecting cables to the ventilator are dead before connecting it! (Separate from the mains with at least a 3 mm contact space, e.g. electric fuse).
-  Each circuit belonging to the ventilator must be equipped with fault current protection (e.g. FI switch).
-  Electrical connection only by an electrician!

Additional installations and/or electrical components are not permitted!

Wiring diagrams for further ventilator functions on request!

- 2** • **Continuous operation 30 m³/h, switchable to 60m³/h or 100 m³/h** (Ventilator types ... 30/60)
- **Run-out time controlled 60 m³/h or 100 m³/h** (Ventilator types ... 60ZII; ... 100ZII)
 - **Continuous operation 30 m³/h, with switchable run-out time controlled 60m³/h or 100 m³/h** (Ventilator types ... 30/60ZII; ... 30/100ZII)

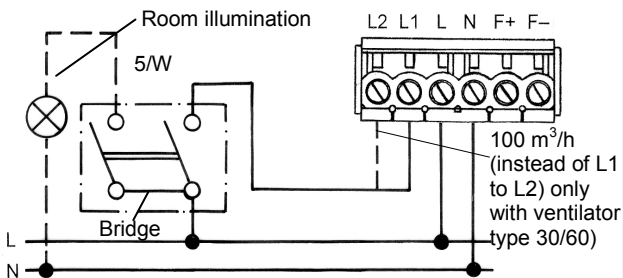

- 1** • **Two-step operation, switchable to 60 m³/h** (Ventilator types ... 30/60)

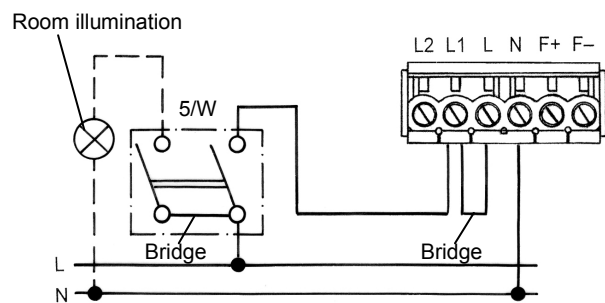

- 3** **With movement detector**

Note: For all circuits with movement detector
(Ventilator types ... 60BZII; ... 100BZII; ... 30/60BZII; ... 30/100BZII; ... 30/60B)

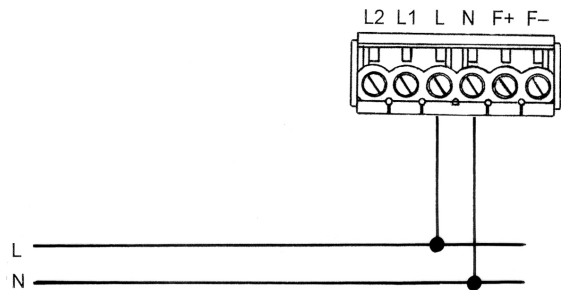

- 4** • **Two-step operation, switchable to 60 m³/h and 100 m³/h ON/OFF** (Ventilator types ... 30/60)

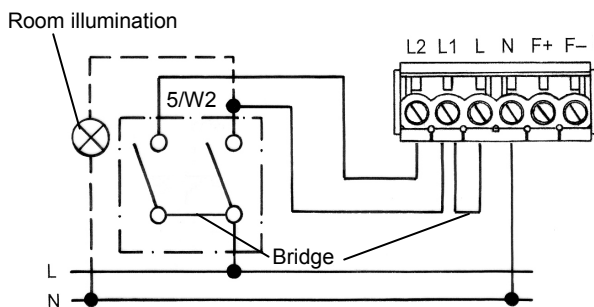

- 5** • **Three-step operation, continuous operation 30 m³/h, switchable to 60 m³/h and 100 m³/h** (Ventilator types ... 30/60)

Note: Light coupling is not possible

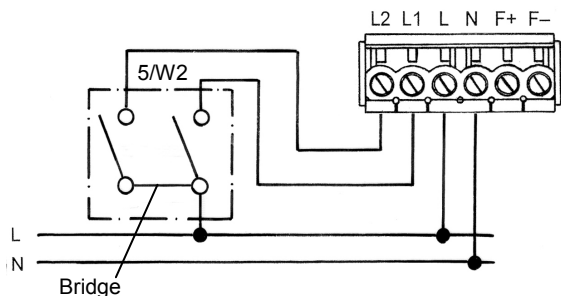

- 6** **With remote control** (ventilator types ... F)

Note: Other circuits, e.g. via L1 or L2, are possible. Remote control always has priority

- 0 ≤ 2 V: Ventilator operation acc. to switch position
- > 2 ≤ 4 V: Ventilator OFF
- > 4 ≤ 6 V: 30 m³/h
- > 6 ≤ 8 V: 40 m³/h
- > 8 ≤ 10 V: 50 m³/h
- > 10 ≤ 12 V: 60 m³/h

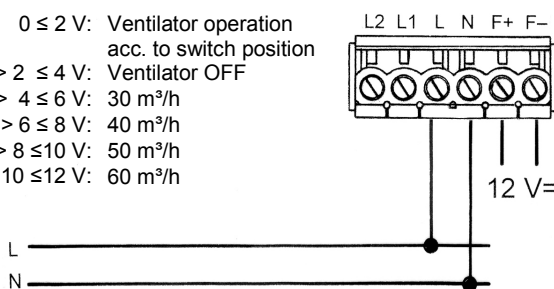

- 7** **Two-room ventilator with run-out time :**

- **Run-out time controlled 100 m³/h, switch-off in each of 2 rooms** (Ventilator types ... 100ZII)
- **Continuous operation 40 m³/h with run-out time controlled 100 m³/h, switch-off in each of 2 rooms** (Ventilator types ... 30/100ZII)

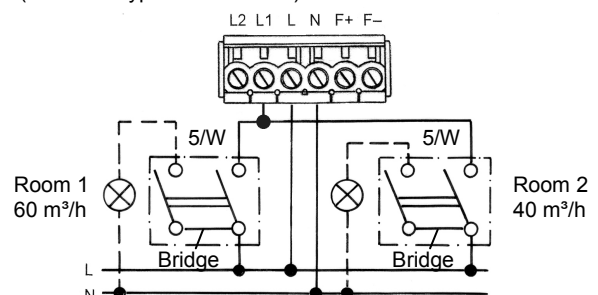

8 Humidity control (ventilator types...FK)

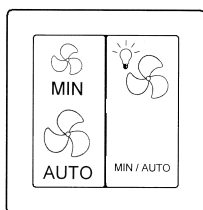

Switch
LUNOS type 5/W2 FK
Order no.: 039 840

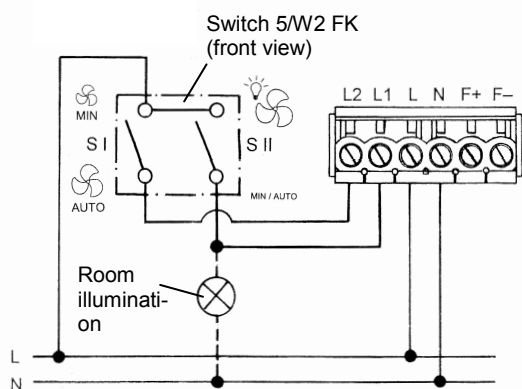

Rocker switch function description S I:



MIN

LOWERING OPERATION:

Volume flow 30m³/h, independent of the room air humidity and room temperature; function active only in the "winter months" October to April



AUTO

HUMIDITY CONTROL:

Volume flow 30/40/50/60 m³/h, humidity control active; function active only in the "winter months" October to April.

Rocker switch function description S II:



MIN / AUTO

Required ventilation ON:

Volume flow 60 m³/h, possible coupling with the light level.

The ventilation with 60 m³/h, by means of a priority control circuit, overrides the operating modes "Lowering operation" and "Humidity control", as well as the automatic summer/winter changeover.

Required ventilation OFF:

Fan runs in automatic summer/winter operation according to setting of the rocker switch S I.

Remote control: Ventilator type ... FK is remote controllable via the F+ and F- connections and with 0 to 12 V.
0 ≤ 2 V: Ventilator operation according to the mains connection; > 2 ≤ 4 V: ventilator OFF; > 4 ≤ 6 V: 30 m³/h; > 6 ≤ 8 V: 40 m³/h; > 8 ≤ 10 V: 50 m³/h; > 10 ≤ 12 V: 60 m³/h

Temperature switch-off: The ventilator switches off when the room temperature drops below 15°C for more than 1 hour and so helps to avoid freezing of the heating. When 17°C is exceeded, it switches on again.

Note: LUNOS standardly supplies an adhesive label set for marking switch positions when series switches from an installation-switch manufacturer are used.

Caution! Ventilators with humidity control optimally adjust the exhaust air volume flow by means of the room air humidity and temperature

The fan has an automatic summer/winter switchover. The illuminated display lights up green with active humidity control and red with clogged filter. The fan runs from May to September in summer operation and from October to April in winter operation. Using an integrated supply-voltage-independent clock, the fan "knows" which month it is. During the cold season and the transitional period, an excess humidification of the apartment is prevented and thus building damage and mold avoided. The system is controlled automatically and, by means of continuous adaptation of the exhaust air volume flow to the room air humidity and room temperature, it guarantees optimum comfort in the room to be ventilated. In this way, only as much ventilation as necessary, but as little ventilation as possible, is ensured and thus energy is saved. The fan never switches off completely in order to ensure a minimum air change. During summer months, the increased exterior air humidity does not make an increased level of ventilation appropriate. The automatic summer/winter changeover is overridden by operation with the rocker switch S I of the switch 5/W2 FK.

9 Two room ventilator

- One step operation, switchable to 100 m³/h from two rooms (ventilator type ... 30/60)

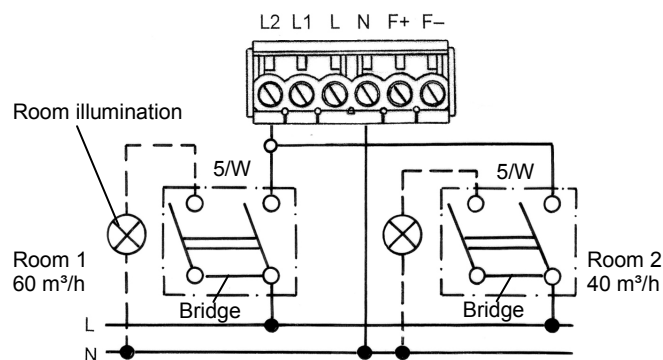

10 Two room ventilator

- Continuous operation 60 m³/h, switchable to 100 m³/h from two rooms (ventilator type ... 30/60)

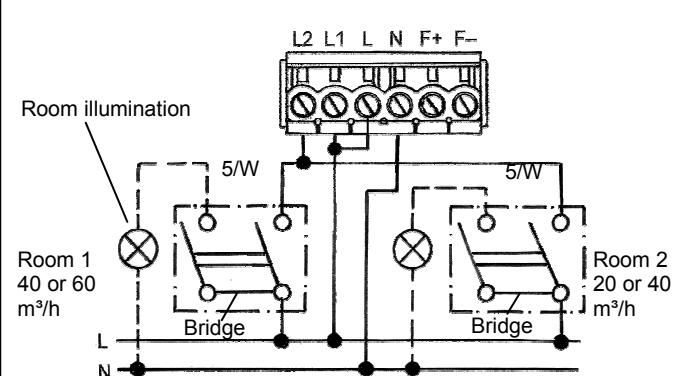

Run-out time setting: For ventilators with run-out time 5/ZII

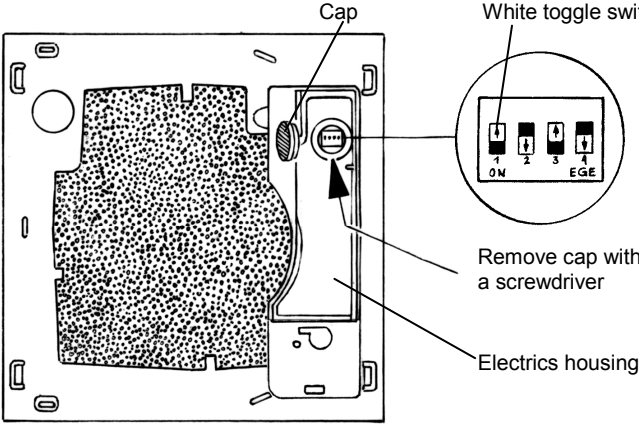

Cap
White toggle switch
Remove cap with a screwdriver
Electrics housing

Caution! Only adjust the switch when ventilator is in the dead condition!

Factory settings:

- Switch-on delay 120 sec
- Run-out time 15 min
- Inverse operation OFF
- Interval switching OFF

To change settings:

1. Take the front cover plate off
2. Draw the cap off of the electrics housing
3. Make the wanted settings
4. Re-assemble in the opposite succession

↓	↑	↓	↑	Interval ON every 4 hrs. for 30 min*
↑	↓	↓	↑	Interval OFF
↓	↓	↓	↓	Run-out time 15 min
↓	↑	↓	↓	Run-out time 6 min
↓	↓	↓	↓	Inverse operation 30 min after run-down after the room is left*
↓	↓	↑	↓	Inverse operation OFF
↓	↓	↓	↓	Switch-on delay 120 sec
↓	↓	↓	↑	Switch-on delay 0 sec
1	2	3	4	* Independent of the set adjusted run-out time

Filter change

Ventilator with movement detector:
Button and illuminated display are in the grid cover frame

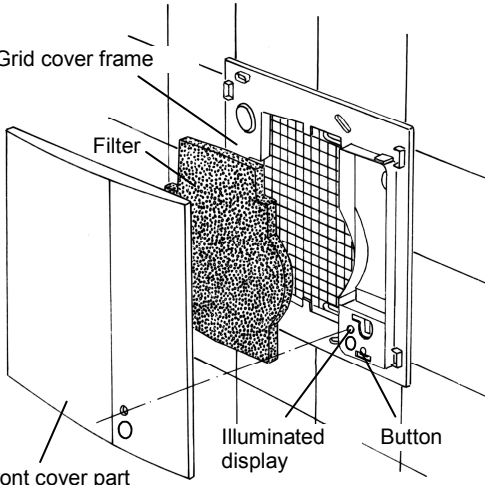

- Continuous red light up of illuminated display indicates that the filter is dirty
- Take of the front cover plate, remove filter. Insert new or cleaned filter. Dirty filters can be cleaned, e.g. in a washing machine.
- Operate button for 3 seconds with a pencil or similar, display illumination turns off
- Replace the front cover plate

Never operate the system without a filter!

Ventilator with step switching, run-out time or humidity control:
Button and illuminated display are in the electrics housing

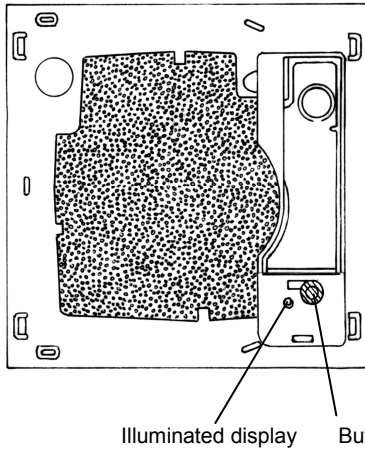

Cleaning

Wipe the front cover plate and grid cover frame with a dry, soft cloth when appropriate.

! Filter change and cleaning are not to be carried out by children or people who cannot manage this with certainty because of their physical, sensorial or mental ability, or their inexperience or lack of appropriate knowledge

Accessory and replacement parts

Filter, pack of 3	2/FSI-R	Order no.	039 721
Silvento decor plate incl. filter display	2/S	Order no.	039 551
Silvento decor plate with movement detector	2/SB	Order no.	039 578
2-Room set consisting of two-room nozzle, film + 2/ZSKA	3/S2	Order no.	039 209
Fire resistant 2-room set consisting of fire resistant nozzle, film + 2/ZSKA	8/B2	Order no.	039 543



LUNOS Lüftungstechnik GmbH für Raumlufsysteme
Wilhelmstr. 31
13593 Berlin
Germany

Tel.: 0 30 / 36 20 01 - 0
Fax: 0 30 / 36 20 01 - 89

Mail: info@lunos.de
Site: http://www.lunos.de